

1

2

3

4

NOTES:

- (1) PURGE ALL WATER SUPPLY LINES TO REMOVE SOLIDS PRIOR TO TOY INSTALLATION.
- (2) PROVIDE ELECTRICAL BOND WITH POOL REBAR.
- (3) INSTALL ALL WATER TOYS PLUMB AND LEVEL.
- (4) PROVIDE STRAINER UPSTREAM OF TOY WITH MAX 1/32" (0.8mm) PERFORATIONS.

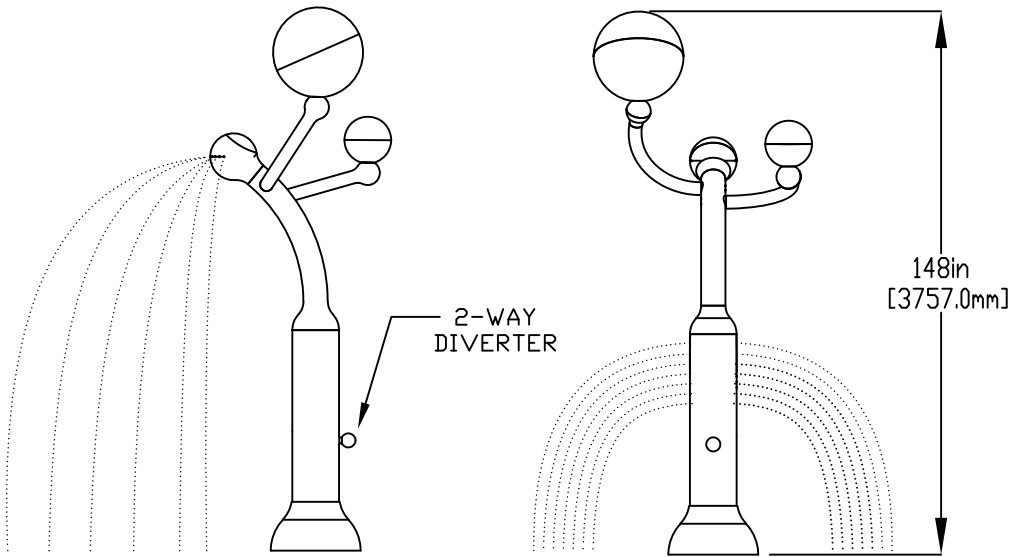
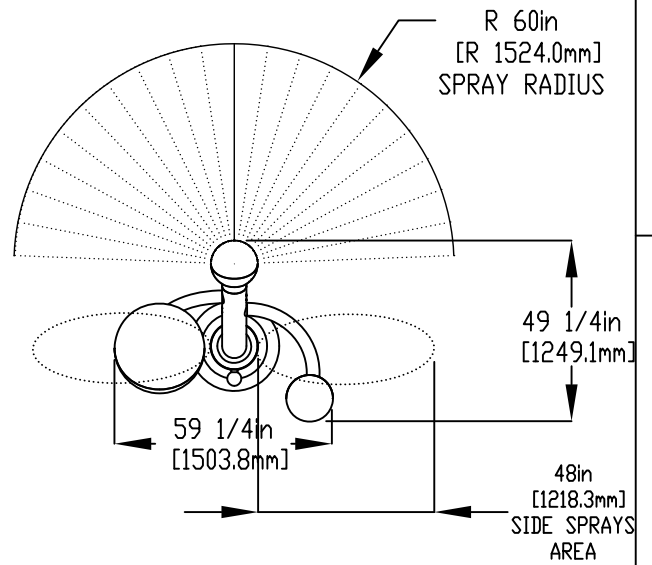
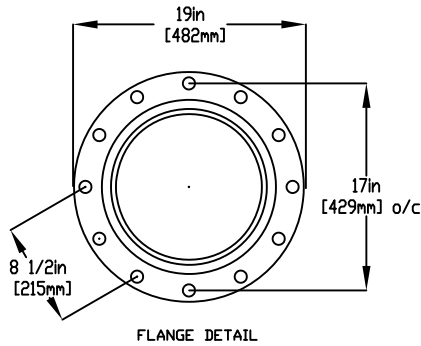

LOWER FLANGE COVER AFTER TOY IS INSTALLED.

5/8" (16mm) X 9" (230mm) 316SS, THREADED ROD, C/W FENDER WASHER, LOCK WASHER & NUT (X6), MINIMUM 6" (150mm) EMBEDMENT. EPOXY SET ANCHOR ADHESIVE TO BE PROVIDED BY CONTRACTORS

1" (25mm) FLEX HOSE PROVIDED BY EMPEX.

2" (50mm) COUPLING  
 2" (50mm) - 1" (25mm) REDUCER  
 1" (25mm) HOSE BARB & SS CLAMP TO BE PROVIDED BY CONTRACTOR

WATERFEED  
 2" (50mm) PVC SHC 40 PIPE EXTENDED 6" (152mm) ABOVE SLAB.

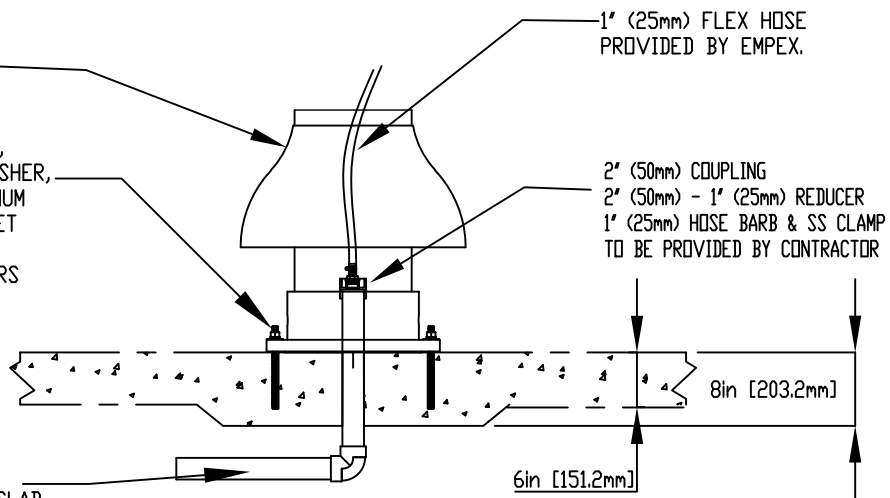

Notes: Overall dimensions of toys are approximate.  
 Approximate Weight: 185lbs / 84.1kgs

© EMPEX WATERTOYS



WATER SUPPLY

30 gpm @ 25 psi  
 1.89L/S @17.5m

AQUABAT #3

AB103

3/31/2020

SCALE:

Sheet 1 of 1

1

2

3

4