

1

2

3

4

NOTES:

(1) PURGE ALL WATER SUPPLY LINES TO REMOVE SOLIDS PRIOR TO TOY INSTALLATION.

(2) PROVIDE ELECTRICAL BOND WITH POOL REBAR.

(3) INSTALL ALL WATER TOYS PLUMB AND LEVEL.

(4) PROVIDE STRAINER UPSTREAM OF TOY WITH MAX 1/32" (0.8mm) PERFORATIONS.

A

A

ø30in [762.0mm] SPRAY DIAMETER

[323.85mm] ø 12.75in

B

B

C

C

35 3/4in [908.6mm]

[508.00mm] 20.00in

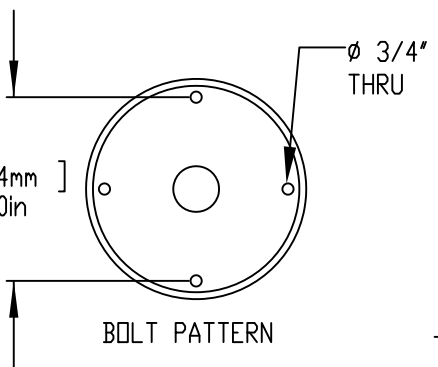

D

D

LOWER TOY AFTER HOSE CONNECTION AND BOLT TO BASE

1" (25mm) FLEX HOSE SUPPLIED BY EMPEX

2" (50mm) COUPLING
2" (50mm) TO 1" (25mm) REDUCER
1" (25mm) HOSEBARB & SS CLAMP TO BE PROVIDED BY CONTRACTOR

E

E

1/2" (13mm) x 8" (203MM) 316SS THREADED ROD, C/W FENDERWASHER, & LOCKWASHER & NUT (x4), MINIMUM 6" (152mm) EMBEDMENT, WITH EPOXY SET ANCHOR ADHESIVE TO BE PROVIDED BY CONTRACTOR

8in [203.1mm]

6in [151.7mm]

WATERFEED
2" (50mm) PVC SCH 40 PIPE EXTENDED 4" (100mm) ABOVE POOL SLAB

Notes: Overall dimensions of toys are approximate.
Approximate Weight: 8lbs / 3.6kgs

© EMPEX WATERTOYS



WATER SUPPLY

30 gpm @ 25 psi
1.89L/S @17.5m

AQUACONE

ABU 101

17/02/22

SCALE:

Sheet 1 of 1

F

F

1

2

3

4