

1

2

3

4

NOTES:

- (1) PURGE ALL WATER SUPPLY LINES TO REMOVE SOLIDS PRIOR TO TOY INSTALLATION.
- (2) PROVIDE ELECTRICAL BOND WITH POOL REBAR.
- (3) INSTALL ALL WATER TOYS PLUMB AND LEVEL.
- (4) PROVIDE STRAINER UPSTREAM OF TOY WITH MAX 1/32" (0.8mm) PERFORATIONS.

70 3/8in
[1786.5mm]
SPRAY
DIAMETER

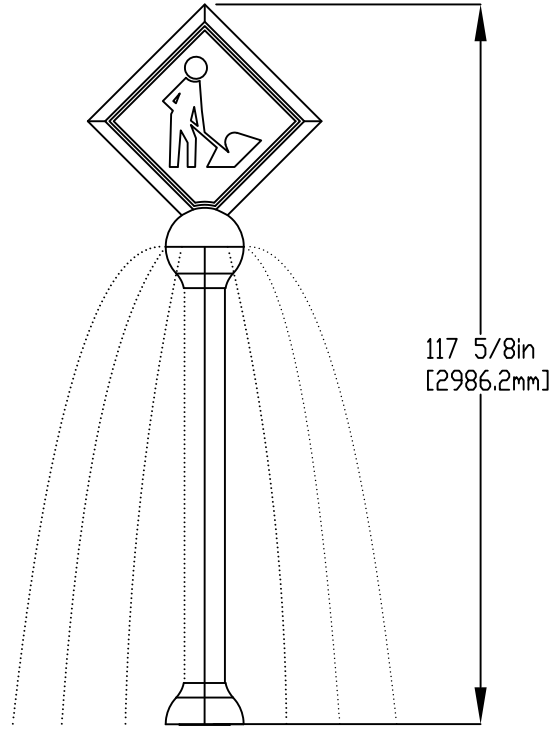
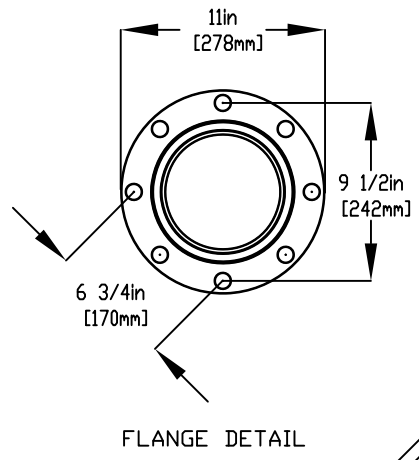
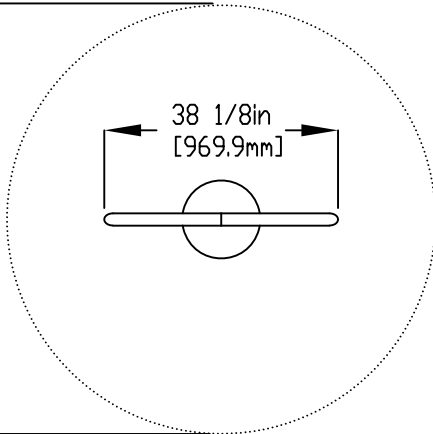

1" (25mm) FLEX HOSE
PROVIDED BY EMPEX

5/8" (16mm) X 9" (229mm) 316SS
THREADED ROD, C/W FENDER WASHER,
LOCK WASHER, & NUT (X6). MINIMUM
6" (152mm) EMBEDMENT, WITH EPOXY SET
ANCHOR ADHESIVE
TO BE PROVIDED BY CONTRACTOR

2" (50mm) COUPLING
2" (50mm) TO 1" (25mm) REDUCER
1" (25mm) HOSEBARB & SS CLAMP
TO BE PROVIDED BY CONTRACTOR

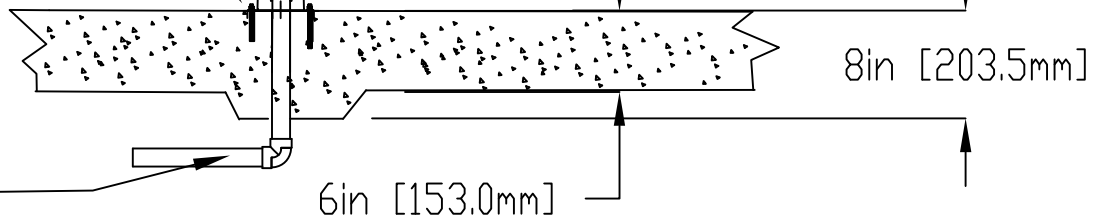

WATERFEED
2" (50mm) PVC40 PIPE
EXTENDED 4" (100mm)
ABOVE SLAB

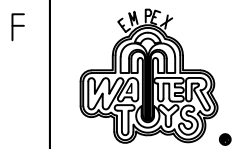

Notes: Overall dimensions of toys are approximate.

© EMPEX WATERTOYS

WATER SUPPLY
30 gpm @ 25 psi
1.89L/S @17.5m

AQUASIGN (Tech Sheet)

ABU108

18/02/2022

SCALE:

Sheet 1 of 1

1

2

3

4