

1

2

3

4

NOTES:

- (1) PURGE ALL WATER SUPPLY LINES TO REMOVE SOLIDS PRIOR TO TOY INSTALLATION.
- (2) PROVIDE ELECTRICAL BOND WITH POOL REBAR.
- (3) INSTALL ALL WATER TOYS PLUMB AND LEVEL.
- (4) PROVIDE STRAINER UPSTREAM OF TOY WITH MAX 1/32" (0.8mm) PERFORATIONS.

R30in [R759.3mm] SPRAY RADIUS

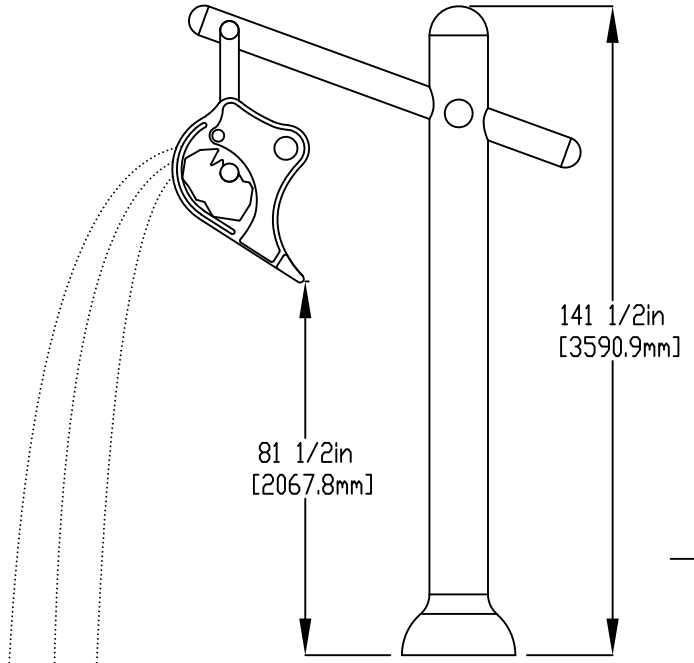
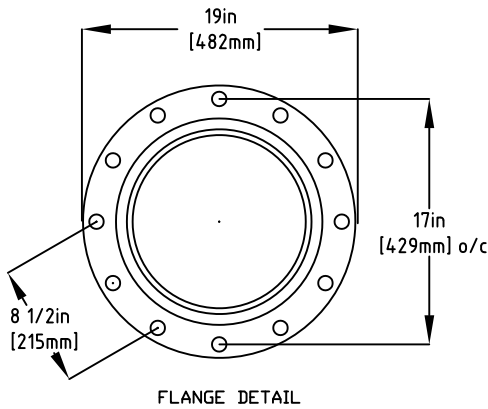
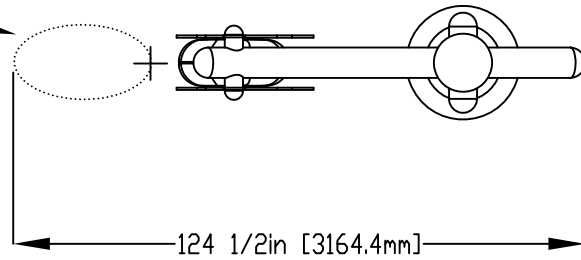

5/8" (16mm) X 9" (229mm) 316SS THREADED ROD, C/W FENDER WASHER, LOCK WASHER & NUT (X6). MINIMUM 6" (152mm) EMBEDMENT, EPOXY SET ANCHOR ADHESIVE TO BE PROVIDED BY CONTRACTOR

1" (25mm) FLEX HOSE PROVIDED BY EMPEX

2" COUPLING 2" (50mm) TO 1" (25mm) REDUCER 1" (25mm) HOSEBARB & SS CLAMP TO BE PROVIDED BY CONTRACTOR

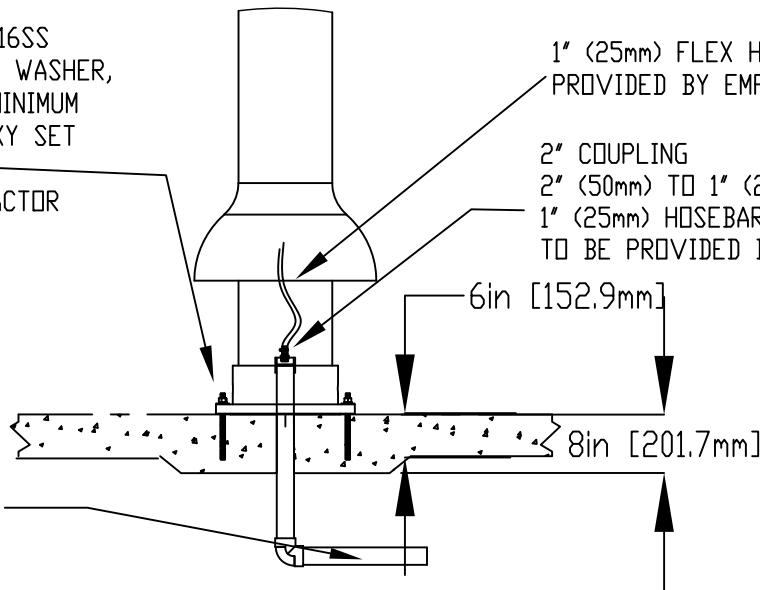

2"(50mm) PVC SCH 40 WATERFEED EXTENDED 6" (150mm) ABOVE POOL SLAB

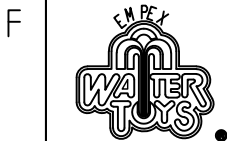

Notes: Overall dimensions of toys are approximate.

© EMPEX WATERTOYS

WATER SUPPLY

30 gpm @ 25 psi  
1.89L/S @17.5m

AQUADIG

ABU109

1/3/2020

SCALE:

Sheet 1 of 1

1

2

3

4