

1

2

3

4

NOTES:

- (1) PURGE ALL WATER SUPPLY LINES TO REMOVE SOLIDS PRIOR TO TOY INSTALLATION.
- (2) PROVIDE ELECTRICAL BOND WITH POOL REBAR.
- (3) INSTALL ALL WATER TOYS PLUMB AND LEVEL.
- (4) PROVIDE STRAINER UPSTREAM OF TOY WITH MAX 1/32" (0.8mm) PERFORATIONS.

A

A

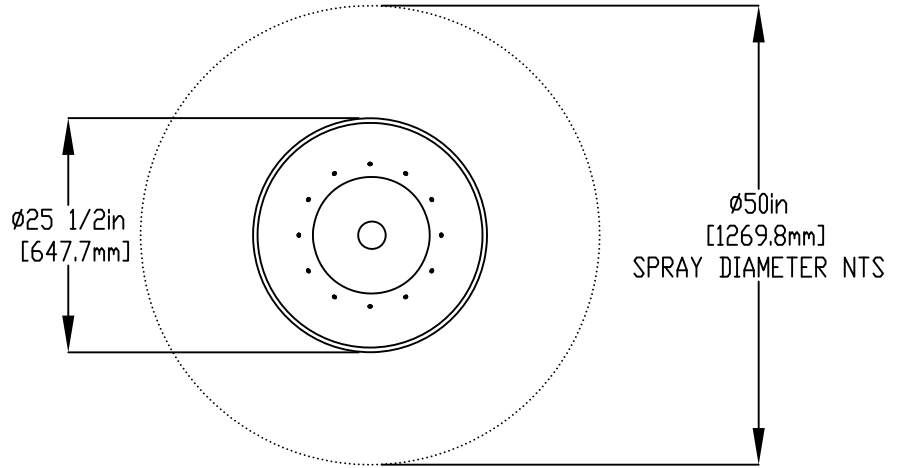

B

B

C

C

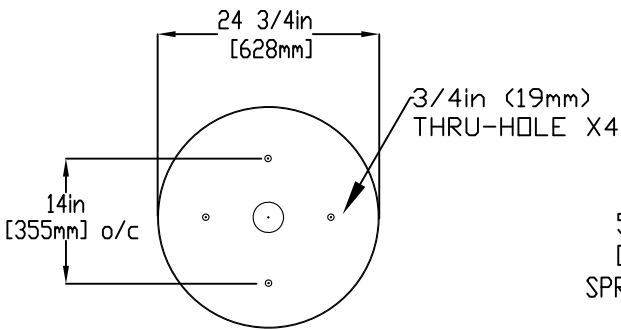

MOUNTING PLATE DETAIL

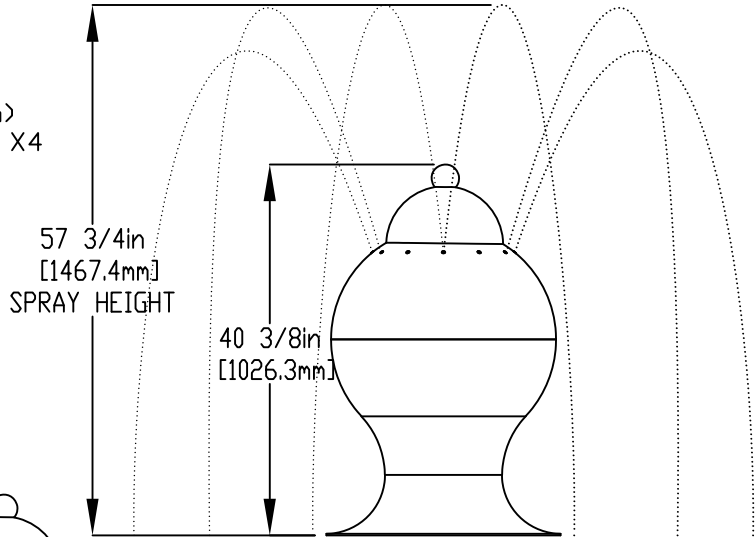

D

D

E

E

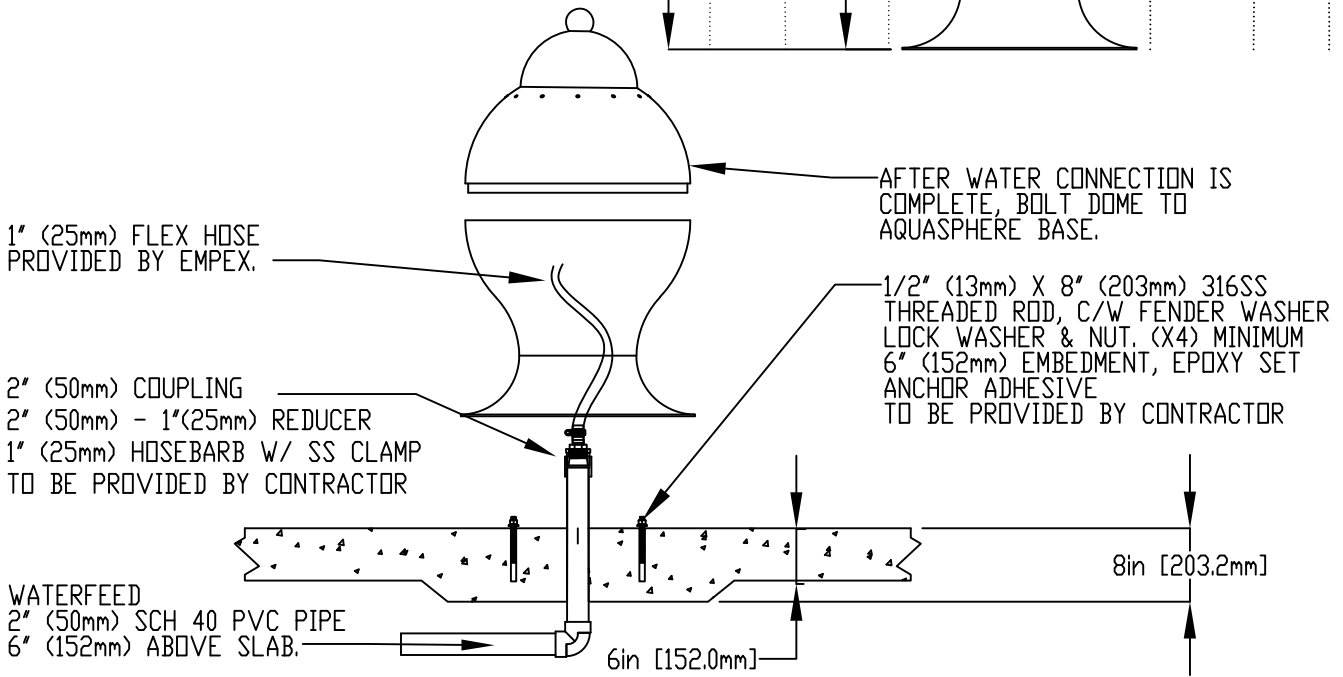

F

F



Notes: Overall dimensions of toys are approximate.  
Approximate Weight: 42lbs / 19.1kgs

© EMPEX WATERTOYS

WATER SUPPLY  
30 gpm @ 25 psi  
1.89L/S @17.5m

AQUAGUM

AD104

01/05/2020

SCALE:

Sheet  
1 of 1

1

2

3

4