

NOTES:

- (1) PURGE ALL WATER SUPPLY LINES TO REMOVE SOLIDS PRIOR TO TOY INSTALLATION.
- (2) PROVIDE ELECTRICAL BOND WITH POOL REBAR.
- (3) INSTALL ALL WATER TOYS PLUMB AND LEVEL.
- (4) PROVIDE STRAINER UPSTREAM OF TOY WITH MAX 1/32" (0.8mm) PERFORATIONS.

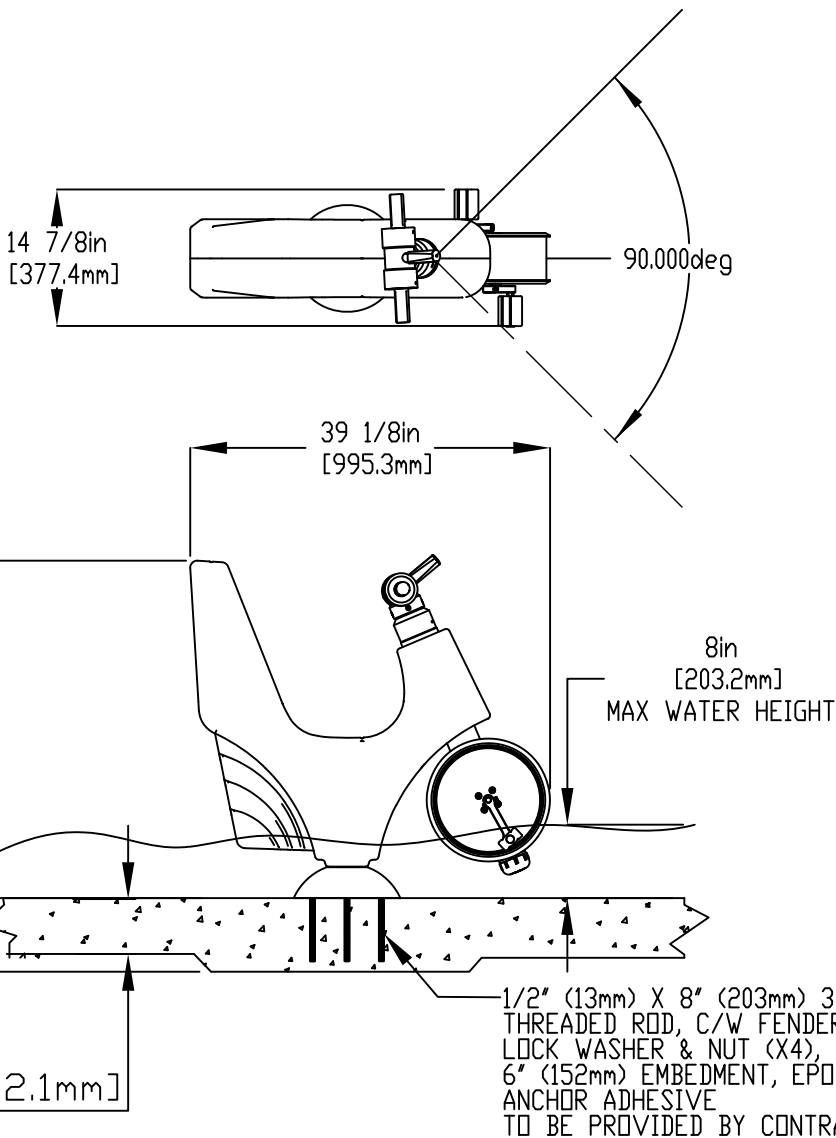

FLANGE BOLT PATTERN  
MIN 4 ANCHORS

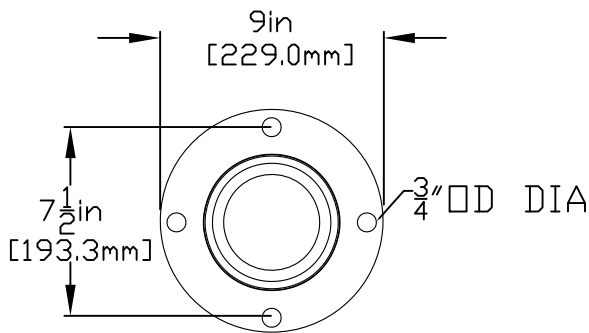

FLANGE DETAIL

Notes: Overall dimensions of toys are approximate.  
Approximate Weight: 42lbs / 19.1kgs

© EMPEX WATERTOYS



WATER SUPPLY  
N/A

WATERBIKE DOLCE

AD201

01/05/2020

SCALE:

Sheet  
1 of 1