

NOTES:

\*RECOMMENDED TO BE INSTALLED ON LEVELLED AREAS ONLY.

(1) PURGE ALL WATER SUPPLY LINES TO REMOVE SOLIDS PRIOR TO TOY INSTALLATION.

(2) PROVIDE ELECTRICAL BOND WITH POOL REBAR.

(3) INSTALL ALL WATER TOYS PLUMB AND LEVEL.

(4) PROVIDE STRAINER UPSTREAM OF TOY WITH MAX 1/32" (0.8mm) PERFORATIONS.

A

B

C

D

E

F

A

B

C

D

E

F

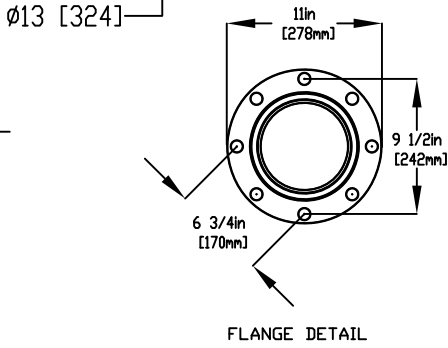
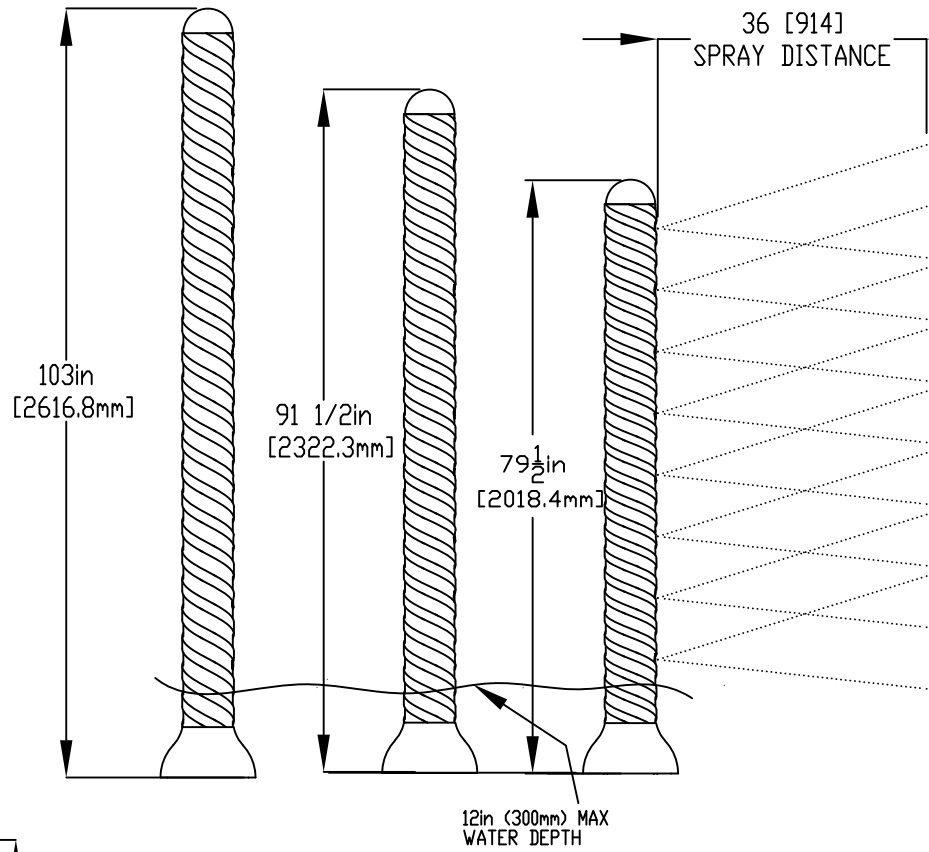

FLANGE COVER TO BE LOWERED AFTER INSTALL

1/2" (13mm) x 8" (203mm) 316SS THREADED ROD, c/w FENDER WASHER, LOCK WASHER & NUT (X4) MINIMUM 6" (152mm) EMBEDMENT, EPOXY SET ANCHOR ADHESIVE TO BE PROVIDED BY CONTRACTOR

ENSURE LEVEL & PLUMB 6" (152mm) X 1/8" (3mm) GASKET TO BE INSTALLED UNDER FLANGE PROVIDED BY EMPES

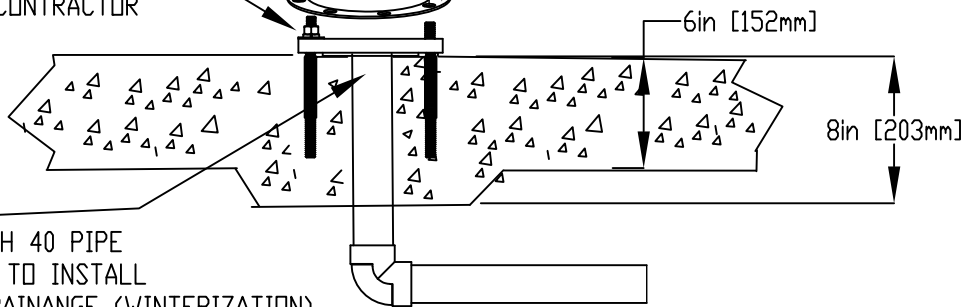

WATERFEED 2" (50mm) PVC SCH 40 PIPE CUT CLOSE PRIOR TO INSTALL TO ALLOW FOR DRAINAGE (WINTERIZATION)



Notes: Overall dimensions of toys are approximate. Approximate Weight: 46lbs / 20.9kgs each

© EMPEX WATERTOYS

WATER SUPPLY

20 gpm @ 25 psi  
1.3L/S @17.5m each toy

AQUASPRITZ DOLCE TRIO

AD260-3

09/02/2022

SCALE:

Sheet 1 of 1