

**NOTES:**

\*RECOMMENDED TO BE INSTALLED ON LEVELLED AREAS ONLY.

(1) PURGE ALL WATER SUPPLY LINES TO REMOVE SOLIDS PRIOR TO TOY INSTALLATION.

(2) PROVIDE ELECTRICAL BOND WITH POOL REBAR.

(3) INSTALL ALL WATER TOYS PLUMB AND LEVEL.

(4) PROVIDE STRAINER UPSTREAM OF TOY WITH MAX 1/32" X (0.8mm) PERFORATIONS.

Ø12 3/4in [323.8mm] PLAN VIEW

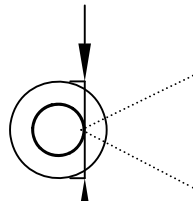

36in [914.4mm] SPRAY DISTANCE

91 1/2in [2325.7mm]

12in (300mm) MAX WATER DEPTH

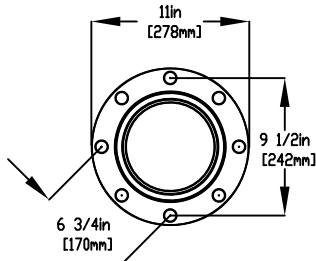
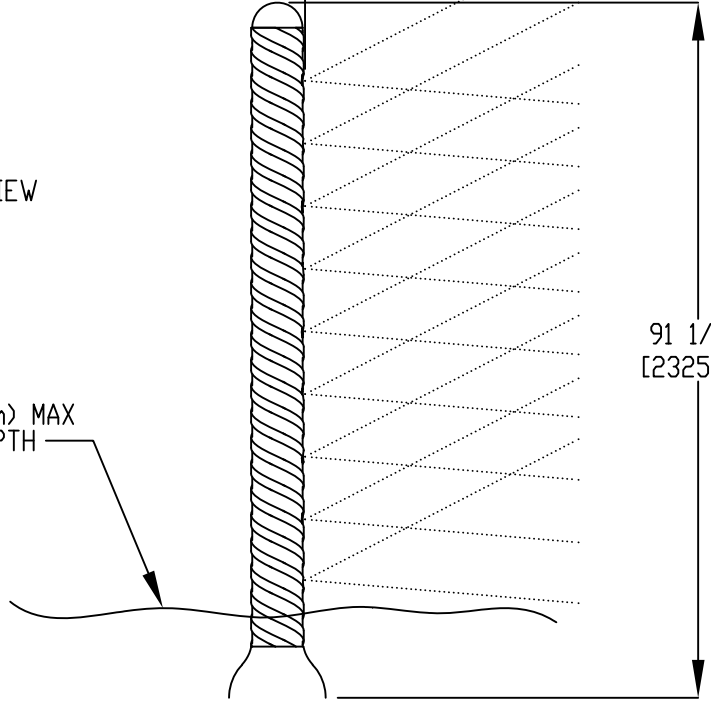

FLANGE DETAIL

1/2" (13mm) STAINLESS STEEL (316) THREADED ROD, FENDER WASHER, LOCK WASHER & NUT. SUGGESTED THREADED ROD LENGTH 9" (230mm) WITH 6" (150mm) EMBEDMENT. USE MIN 4 ANCHORS. PROVIDED BY CONTRACTOR

ENSURE LEVEL & PLUMB 6" (152mm) X 1/8" GASKET INSTALL UNDER FLANGE PROVIDED BY EMPEX

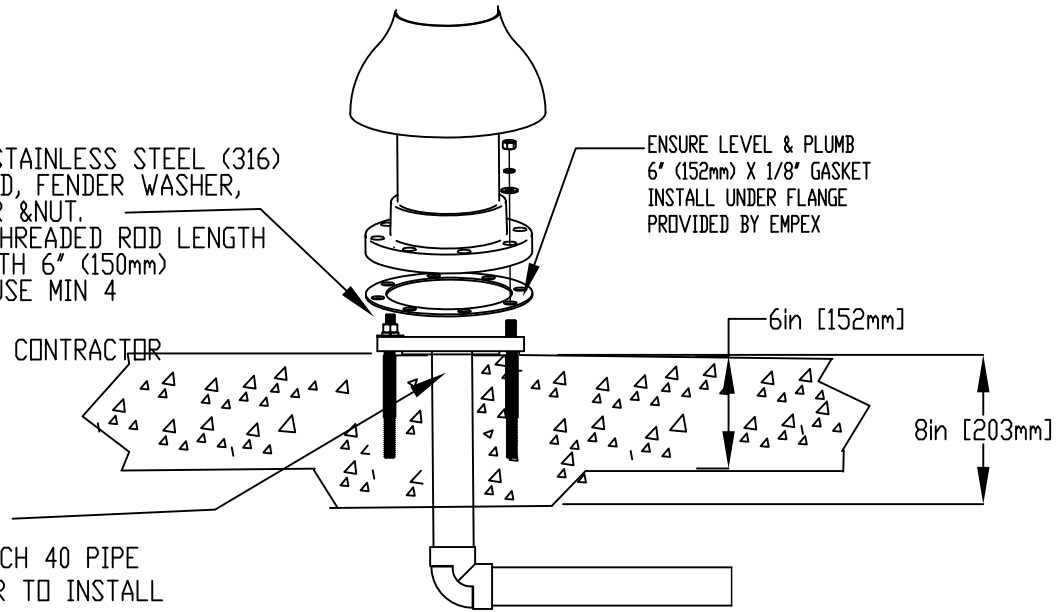

WATERFEED 2" (50mm) PVC SCH 40 PIPE CUT CLOSE PRIOR TO INSTALL TO ALLOW FULL DRAINAGE (WINTERIZATION)

Notes: Overall dimensions of toys are approximate.

© EMPEX WATERTOYS



WATER SUPPLY

20 gpm @ 25 psi  
1.3L/S @17.5m

MEDIUM AQUASPRITZ DOLCE

AD260M

3/14/2019

SCALE:

Sheet 1 of 1