

NOTES:

*RECOMMENDED TO BE INSTALLED ON LEVELLED AREAS ONLY.

(1) PURGE ALL WATER SUPPLY LINES TO REMOVE SOLIDS PRIOR TO TOY INSTALLATION.

(2) PROVIDE ELECTRICAL BOND WITH POOL REBAR.

(3) INSTALL ALL WATER TOYS PLUMB AND LEVEL.

(4) PROVIDE STRAINER UPSTREAM OF TOY WITH MAX 1/32" (0.8mm) PERFORATIONS.

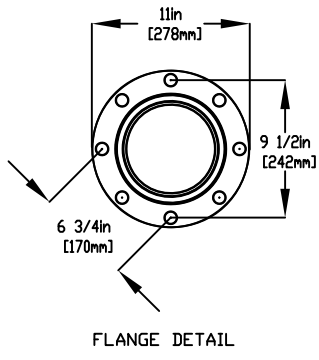
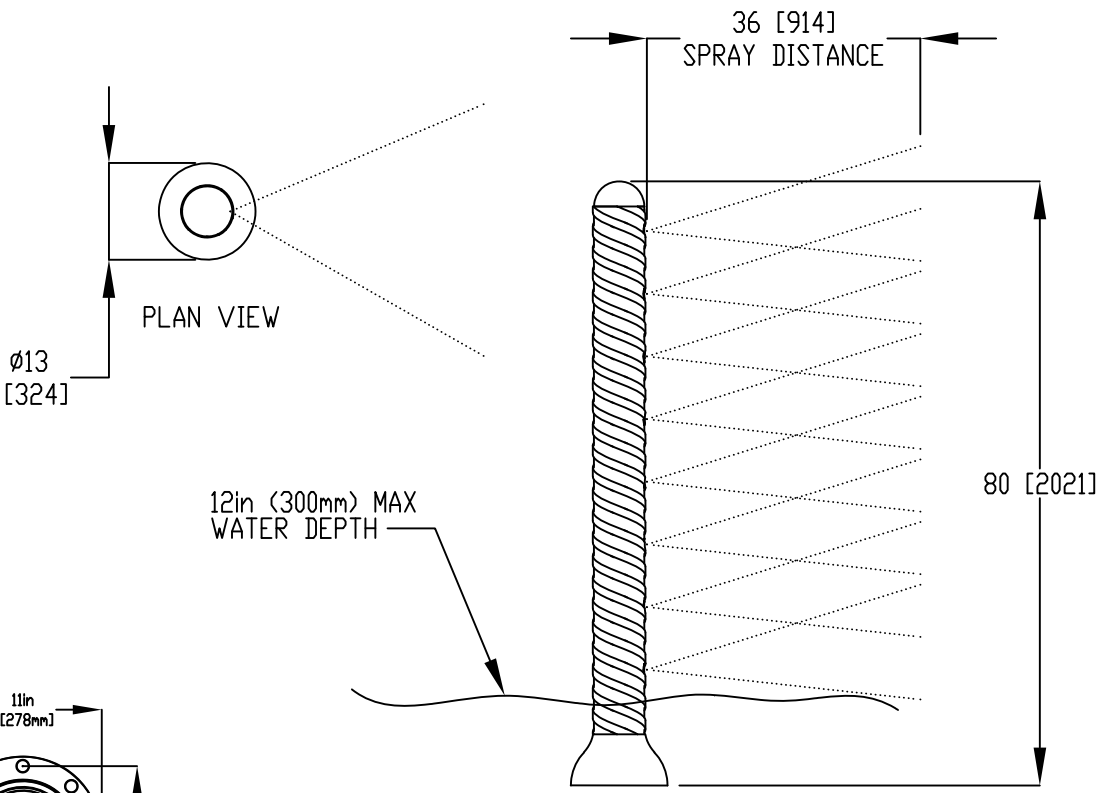

1/2" (13mm) STAINLESS STEEL (316) THREADED ROD, FENDER WASHER, LOCK WASHER & NUT. SUGGESTED THREADED ROD LENGTH 9" (230mm) WITH 6" (150mm) EMBEDMENT. USE MIN 4 ANCHORS.

ENSURE LEVEL & PLUMB
6" (152mm) X 1/8" GASKET
INSTALL UNDER FLANGE
PROVIDED BY EMPEX

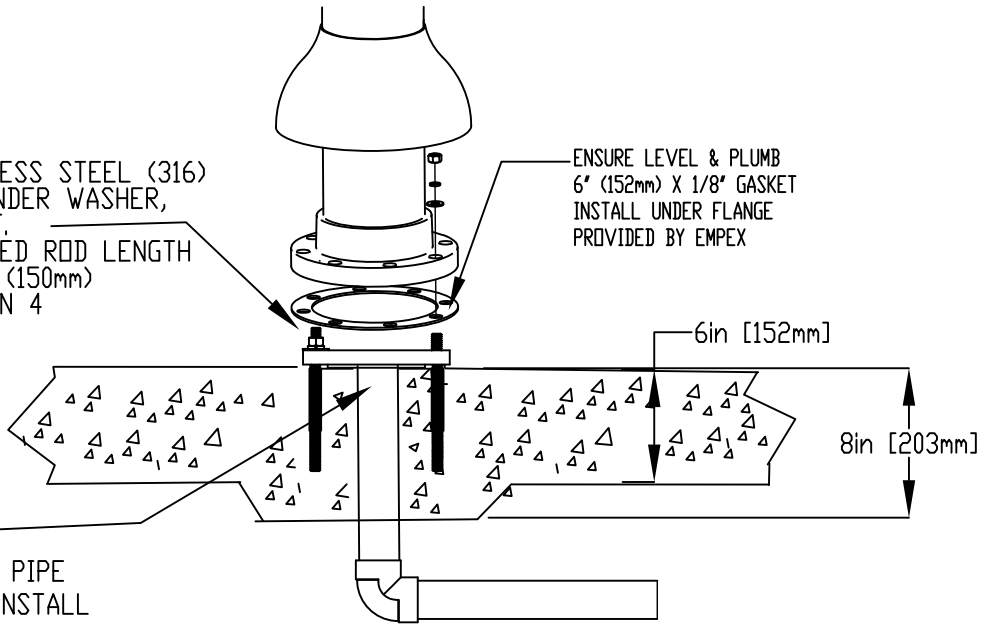

WATERFEED
2" (50mm) PVC SCH 40 PIPE
CUT CLOSE PRIOR TO INSTALL
TO ALLOW FULL DRAINAGE (WINTERIZATION)



Notes: Overall dimensions of toys are approximate.

© EMPEX WATERTOYS

WATER SUPPLY
20 gpm @ 25 psi
1.3L/S @17.5m

AQUASPRITZ DOLCE

AD260S

3/14/2019

SCALE:
1:25

Sheet
1 of 1