

NOTES:

- (1) PURGE ALL WATER SUPPLY LINES TO REMOVE SOLIDS PRIOR TO TOY INSTALLATION.
- (2) PROVIDE ELECTRICAL BOND WITH POOL REBAR.
- (3) INSTALL ALL WATER TOYS PLUMB AND LEVEL.
- (4) PROVIDE STRAINER UPSTREAM OF TOY WITH MAX 1/32" (0.8mm) PERFORATIONS.

A

B

C

D

E

F

A

B

C

D

E

F

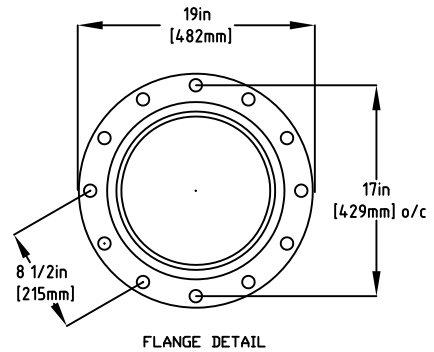
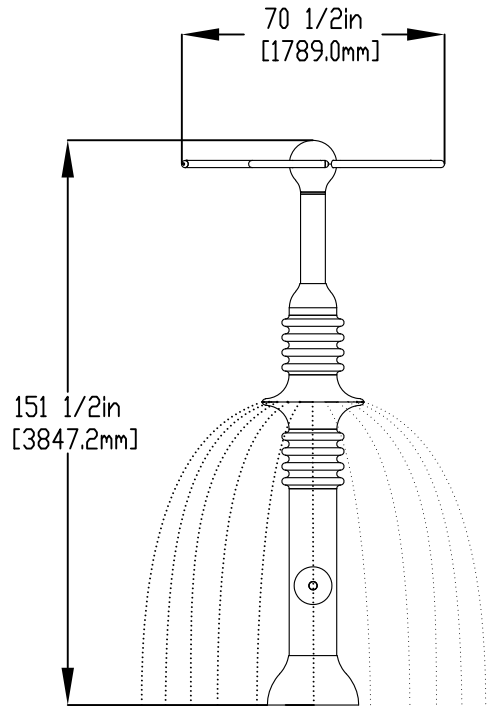
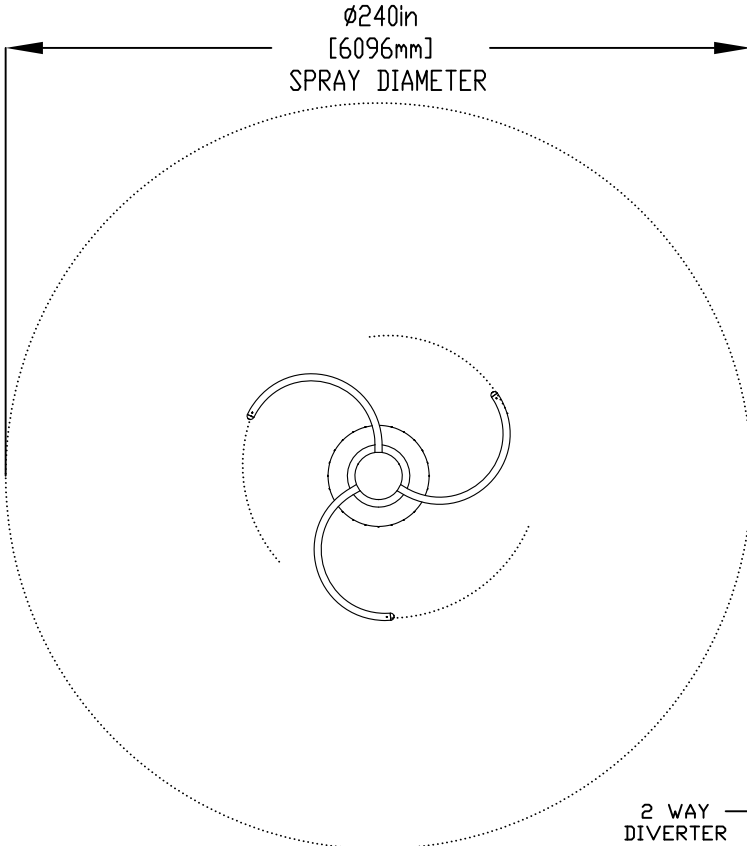

LOWER FLANGE COVER AFTER TOY IS INSTALLED.

5/8" (16mm) x 9" (229MM) 316SS THREADED ROD, C/W FENDER WASHER, LOCK WASHER & NUT (X6), MINIMUM 6" (150mm) EMBEDMENT. EPOXY SET ANCHOR ADHESIVE TO BE PROVIDED BY CONTRACTOR

WATERFEED 2" (50mm) SCH 40 PVC PIPE EXTENDED 6" (152mm) ABOVE SLAB.

2 WAY DIVERTER

1" (25mm) FLEX HOSE PROVIDED BY EMPEX.

2" (50mm) COUPLING
 2" (50mm) - 1" (25mm) REDUCER
 1" (25mm) HOSEBARB W/ SS CLAMP TO BE PROVIDED BY CONTRACTOR

6in [152.3mm]

8in [203.2mm]

Notes: Overall dimensions of toys are approximate.
 Approximate Weight: TBD

© EMPEX WATERTOYS



WATER SUPPLY
 30 gpm @ 25 psi
 1.89L/S @17.5m

AQUASWIRL DOLCE

AD303

08/04/2020

SCALE:

Sheet
 1 of 1