

1

2

3

4

NOTES:

- (1) PURGE ALL WATER SUPPLY LINES TO REMOVE SOLIDS PRIOR TO TOY INSTALLATION.
- (2) PROVIDE ELECTRICAL BOND WITH POOL REBAR.
- (3) INSTALL ALL WATER TOYS PLUMB AND LEVEL.
- (4) PROVIDE STRAINER UPSTREAM OF TOY WITH MAX 1/32" (0.8mm) PERFORATIONS.

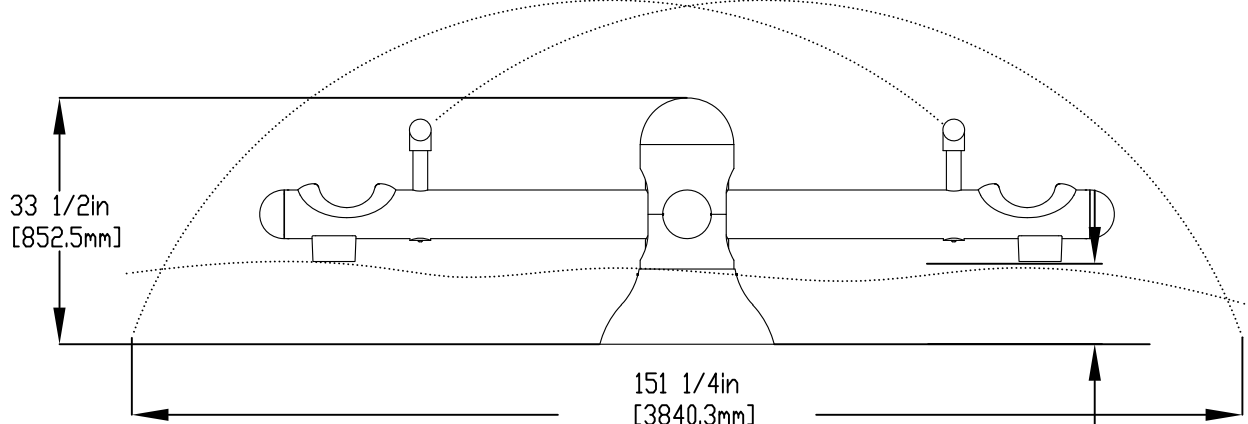
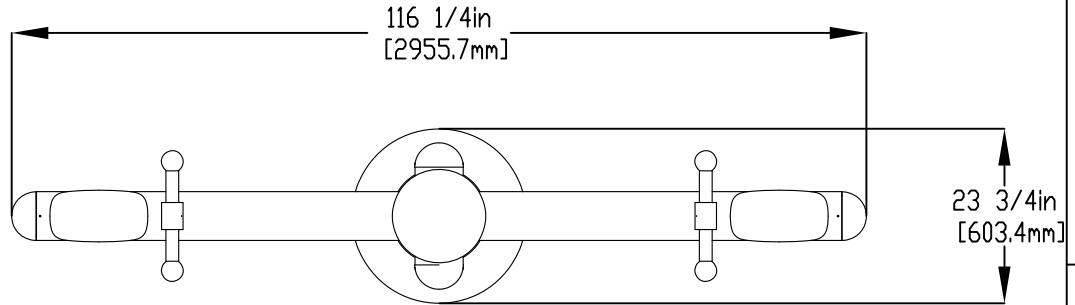

SPRAY DISTANCE NTS

MAX DEPTH
6"-12"
(15mm-305mm)

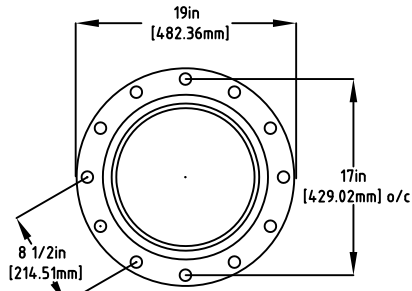

FLANGE DETAIL

1/2" (13mm) X 8" (203mm) 316SS
 THREADED ROD C/W FENDER WASHER,
 LOCK WASHER & NUT (X4), MINIMUM
 EMBEDMENT 6" (152mm), EPOXY SET
 ANCHOR ADHESHIVE
 TO BE PROVIDED BY CONTRACTOR

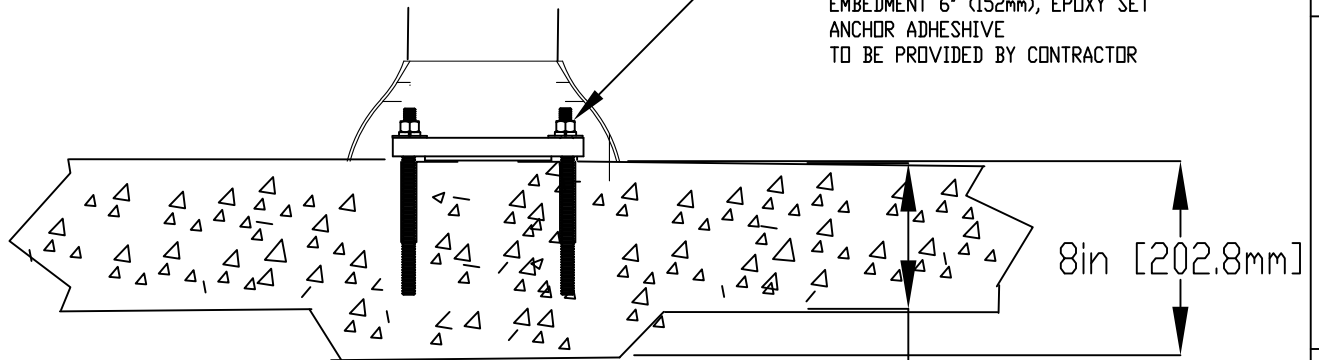

6 in [152.5mm]

8 in [202.8mm]

Notes: Overall dimensions of toys are approximate.
 Approximate Weight: 150lbs / 68.2kgs

© EMPEX WATERTOYS



WATER SUPPLY
 NO EXTERNAL SUPPLY

WATERTOTTER DOLCE

AD311

11/06/2020

SCALE:

Sheet
1 of 1

1

2

3

4