

1

2

3

4

NOTES:

- (1) PURGE ALL WATER SUPPLY LINES TO REMOVE SOLIDS PRIOR TO TOY INSTALLATION.
- (2) PROVIDE ELECTRICAL BOND WITH POOL REBAR.
- (3) INSTALL ALL WATER TOYS PLUMB AND LEVEL.
- (4) PROVIDE STRAINER UPSTREAM OF TOY WITH MAX 1/32" (0.8mm) PERFORATIONS.

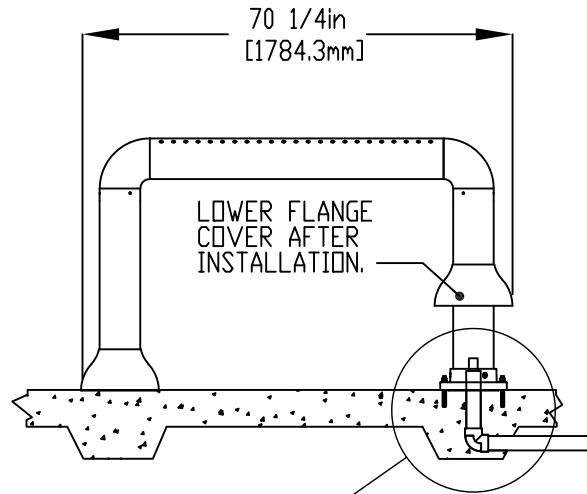
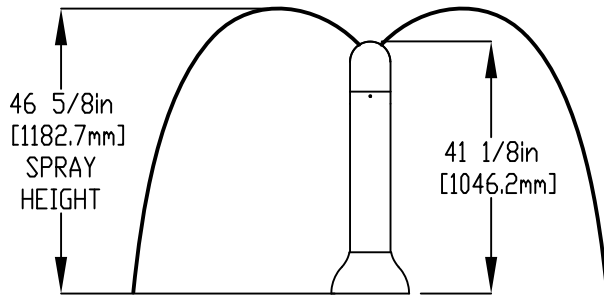
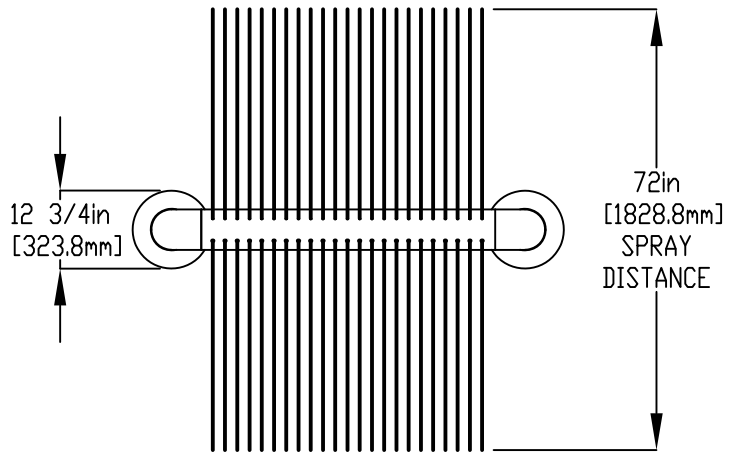

1" (25mm) FLEX HOSE PROVIDED BY EMPEX.

2" (50mm) TO 1" (25mm) REDUCER TO BE PROVIDED BY CONTRACTOR.

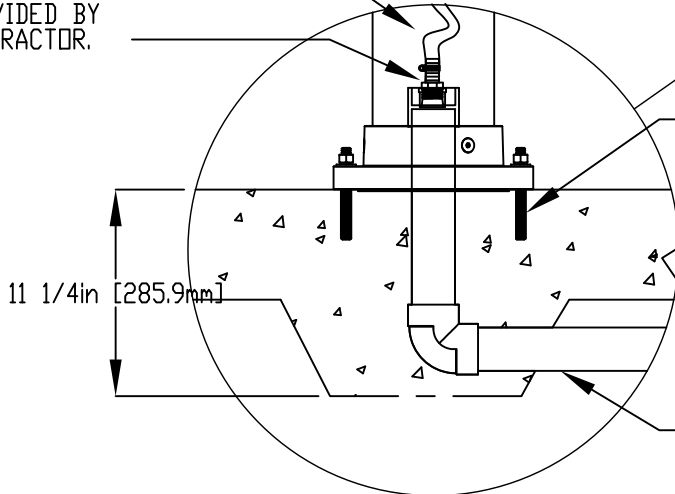

STAINLESS STEEL (316)
 ø 1/2" (13mm) THREADED ROD, WASHER, LOCK WASHER, & NUT.
 6" (150mm) THREADED ROD WITH 4" (100mm) EMBEDMENT. INSTALL MINIMUM 6 ANCHORS PER LEG. TO BE PROVIDED BY CONTRACTOR

2" (50mm) PVC SCH 40 WATERFEED EXTENDED
 6" (150mm) ABOVE POOL SLAB.

A

A

B

B

C

C

D

D

E

E

F

F



Notes: Overall dimensions of toys are approximate.
 Approximate Weight: 36lbs / 16.4kgs

© EMPEX WATERTOYS

WATER SUPPLY

30 gpm @ 25 psi
 1.89L/S @17.5m

AQUAFORM DOLCE

AD371

24/03/21

SCALE:

Sheet 1 of 1

1

2

3

4