

1

2

3

4

NOTES:

(1) PURGE ALL WATER SUPPLY LINES TO REMOVE SOLIDS PRIOR TO TOY INSTALLATION.

(2) PROVIDE ELECTRICAL BOND WITH POOL REBAR.

(3) INSTALL ALL WATER TOYS PLUMB AND LEVEL.

(4) PROVIDE STRAINER UPSTREAM OF TOY WITH MAX 1/32" (0.8mm) PERFORATIONS.

(5) TOY MUST BE INSTALLED ON FLAT SURFACE.

A

B

C

D

E

F

A

B

C

D

E

F

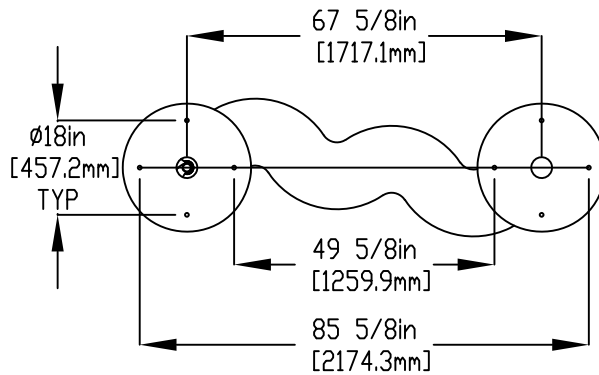
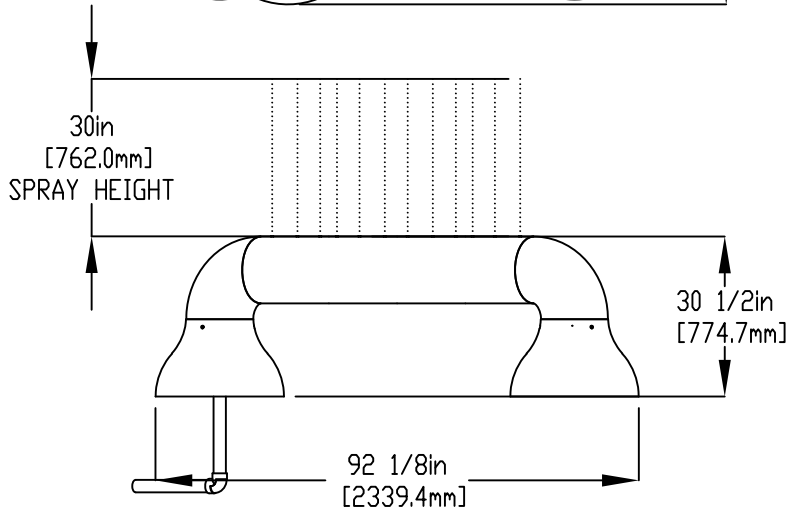
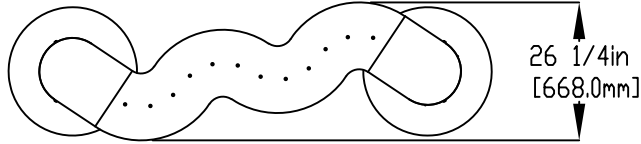

1/2" (13mm) X 8" (203mm) 316SS
 THREADED ROD, C/W FENDER WASHER,
 LACK WASHER & NUT (X4) MINIMUM
 6" (150mm) EMBEDMENT. EPOXY SET
 ANCHOR ADHESIVE
 TO BE PROVIDED BY CONTRACTOR

WATERFEED
 2" (50) PVC SCH 40 PIPE
 6" (152mm) ABOVE SLAB.

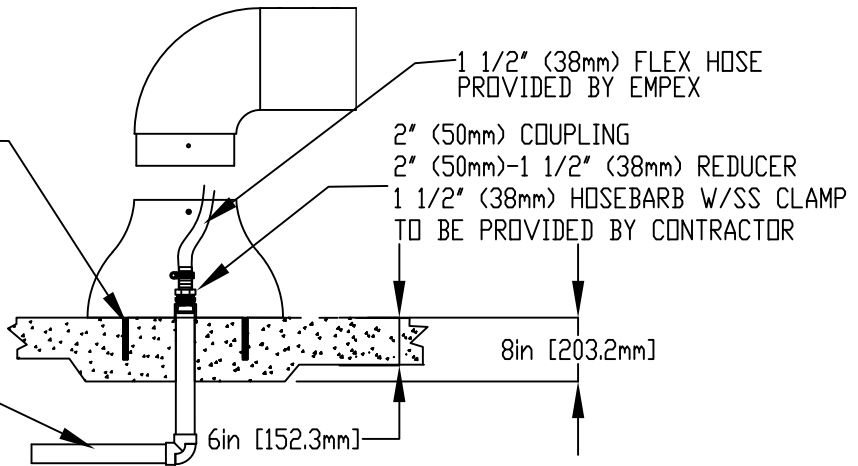

Notes: Overall dimensions of toys are approximate.
 Approximate Weight: 42lbs / 19.1kgs

© EMPEX WATERTOYS



WATER SUPPLY

60 gpm @ 25 psi
 3.8L/S @17.5m

AQUAFLO DOLCE

AD602

05/04/2021

SCALE:

Sheet
1 of 1

1

2

3

4