

1

2

3

4

NOTES:

- (1) PURGE ALL WATER SUPPLY LINES TO REMOVE SOLIDS PRIOR TO TOY INSTALLATION.
- (2) PROVIDE ELECTRICAL BOND WITH POOL REBAR.
- (3) INSTALL ALL WATER TOYS PLUMB AND LEVEL.
- (4) PROVIDE STRAINER UPSTREAM OF TOY WITH MAX 1/32" (0.8mm) PERFORATIONS.

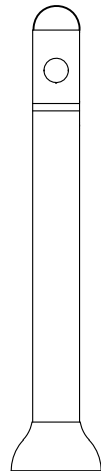
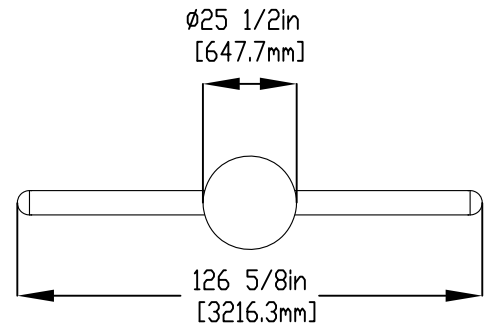
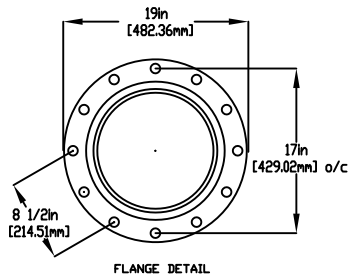

SIDE VIEW

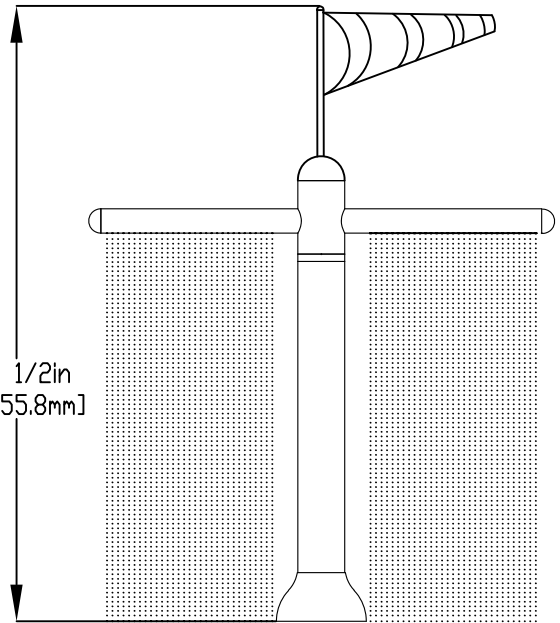

LOWER FLANGE COVER AFTER TOY IS INSTALLED.

5/8" (16mm) X 9" (230mm) 316SS THREADED ROD C/W FENDER WASHER, LOCK WASHER, & NUT (X6). MINIMUM 6" (152mm) EMBEDMENT, EPOXY SET ANCHOR ADHESIVE TO BE PROVIDED BY CONTRACTOR

1 1/2" (38mm) FLEX HOSE PROVIDED BY EMPEX.

2" (50mm) COUPLING  
 2" (50mm)-1 1/2"(38mm) REDUCER  
 1 1/2" (38mm) HOSEBARB W/SS CLAMP TO BE PROVIDED BY CONTRACTOR

WATER FEED  
 2" (50mm) SCH 40 PVC PIPE EXTENDED 6" (152mm) ABOVE SLAB.

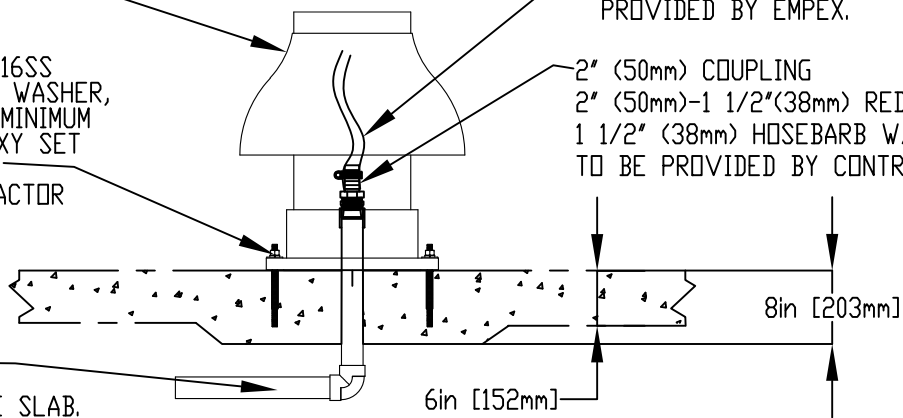

Notes: Overall dimensions of toys are approximate.

© EMPEX WATERTOYS

WATER SUPPLY

50 gpm @ 25 psi  
 3.15 L/S @17.5m

AQUASOC

AE102

27/06/2022

SCALE:

Sheet 1 of 1

1

2

3

4