

NOTES:

- (1) PURGE ALL WATER SUPPLY LINES TO REMOVE SOLIDS PRIOR TO TOY INSTALLATION.
- (2) PROVIDE ELECTRICAL BOND WITH POOL REBAR.
- (3) INSTALL ALL WATER TOYS PLUMB AND LEVEL.
- (4) PROVIDE STRAINER UPSTREAM OF TOY WITH MAX 1/32" (0.8mm) PERFORATIONS.

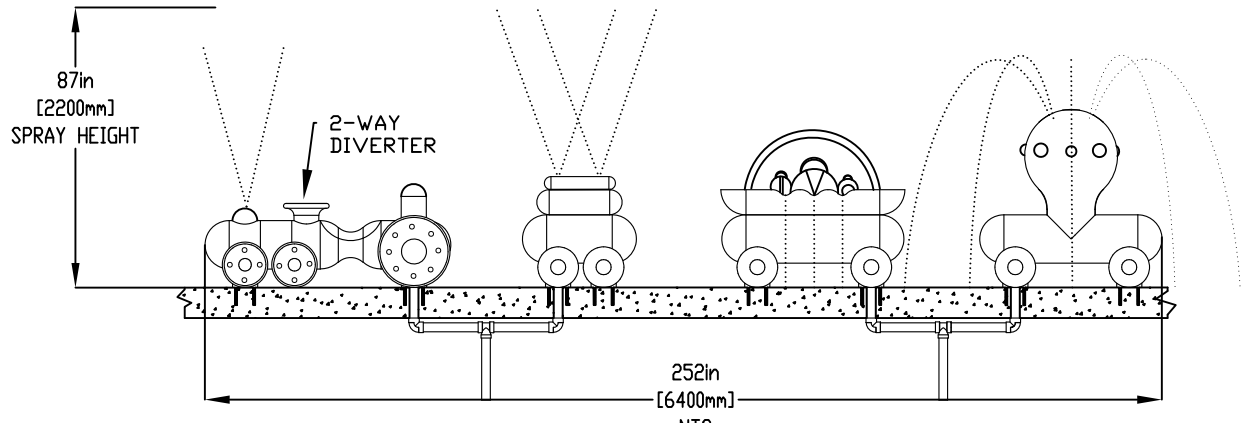

ELEVATION VIEW

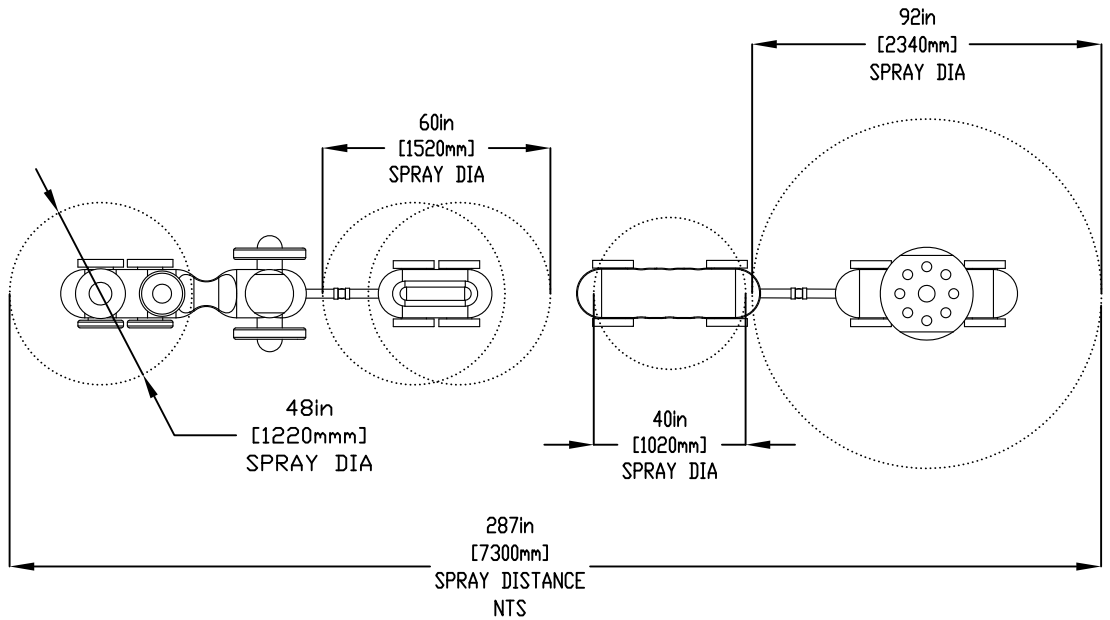
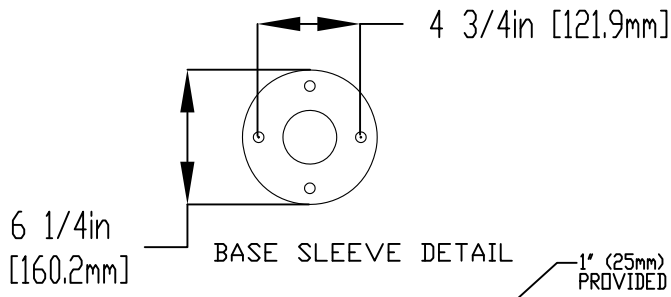

1/2" (13mm) X 8" (203mm) 316SS THREADED ROD, C/W FENDER WASHER, LOCK WASHER, & NUT (X4), MINIMUM 6" (152mm) EMBEDMENT, EPOXY SET ANCHOR ADHESIVE (X8 SETS) TO BE PROVIDED BY CONTRACTOR

1" (25mm) FLEX HOSE PROVIDED BY EMPEX
 2" (50mm) COUPLING
 2" (50mm) TO 1" (25mm) REDUCER
 1" (25mm) HOSEBARB W/SS CLAMP (x4) TO BE PROVIDED BY CONTRACTOR

[203mm] 8in

WATERFEED (X2) SEE ABOVE
 2" (50mm) SCH 40 PVC PIPE EXTENDED 6" (152mm) ABOVE SLAB.

Notes: Overall dimensions of toys are approximate.

© EMPEX WATERTOYS



WATER SUPPLY
 (60ea) 120 gpm @ 25 psi
 (7ea) 13.9L/S @17.5m

AQUATOW

AE107	28/06/2022	SCALE:	Sheet 1 of 1
-------	------------	--------	--------------