

NOTES:

- (1) PURGE ALL WATER SUPPLY LINES TO REMOVE SOLIDS PRIOR TO TOY INSTALLATION.
- (2) PROVIDE ELECTRICAL BOND WITH POOL REBAR.
- (3) INSTALL ALL WATER TOYS PLUMB AND LEVEL.
- (4) PROVIDE STRAINER UPSTREAM OF TOY WITH MAX 1/32" (0.8mm) PERFORATIONS.

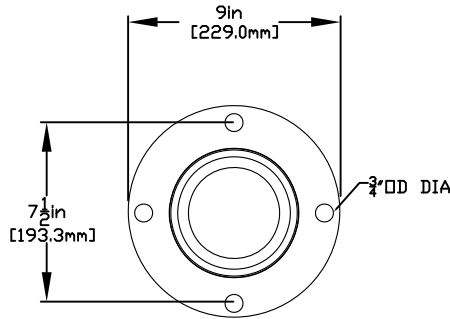

FLANGE DETAIL

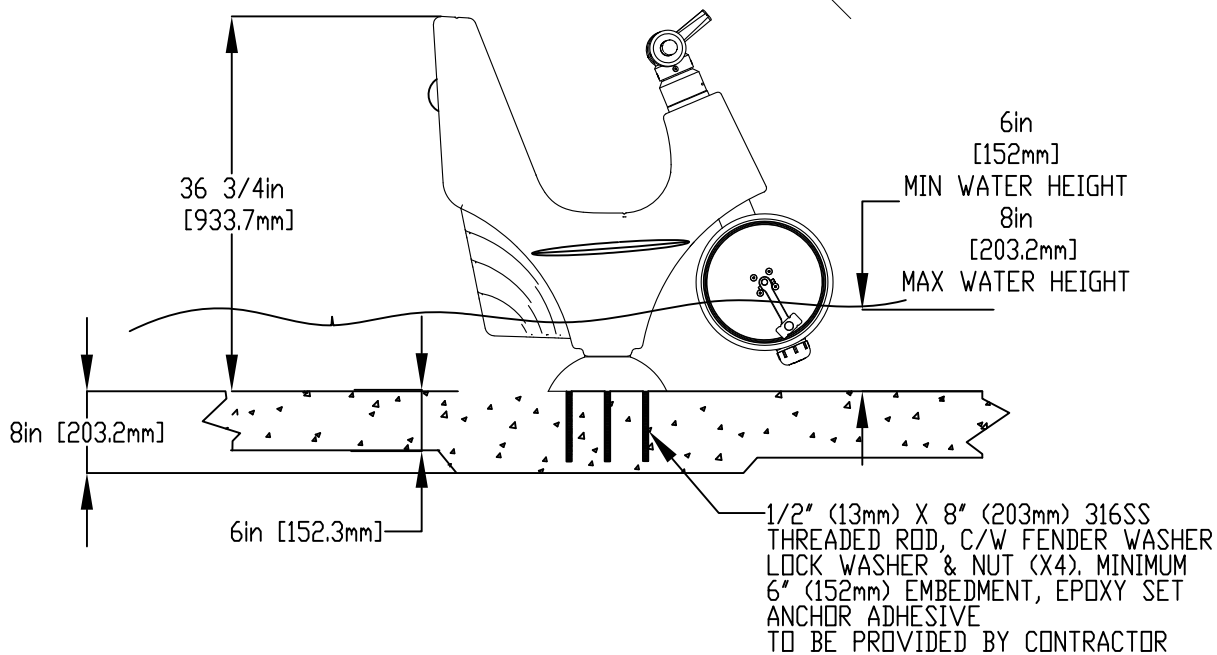
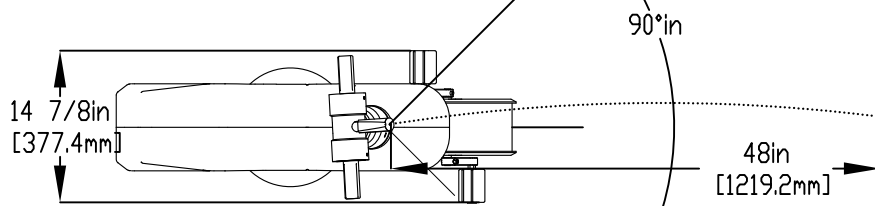

1/2" (13mm) X 8" (203mm) 316SS  
 THREADED ROD, C/W FENDER WASHER  
 LOCK WASHER & NUT (X4). MINIMUM  
 6" (152mm) EMBEDMENT, EPOXY SET  
 ANCHOR ADHESIVE  
 TO BE PROVIDED BY CONTRACTOR

Notes: Overall dimensions of toys are approximate.  
 Approximate Weight: 42lbs / 19.1kgs

© EMPEX WATERTOYS



WATER SUPPLY  
 N/A

WATER BIKE AERO

AE201

16/02/2021

SCALE:

Sheet  
1 of 1