

NOTES:

- (1) PURGE ALL WATER SUPPLY LINES TO REMOVE SOLIDS PRIOR TO TOY INSTALLATION.
- (2) PROVIDE ELECTRICAL BOND WITH POOL REBAR.
- (3) INSTALL ALL WATER TOYS PLUMB AND LEVEL.
- (4) PROVIDE STRAINER UPSTREAM OF TOY WITH MAX 1/32" (0.8mm) PERFORATIONS.

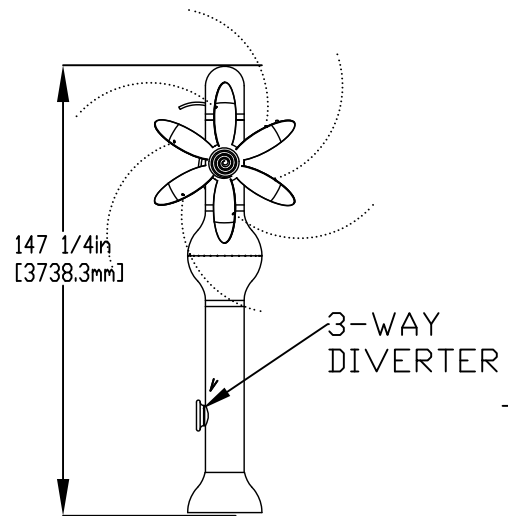
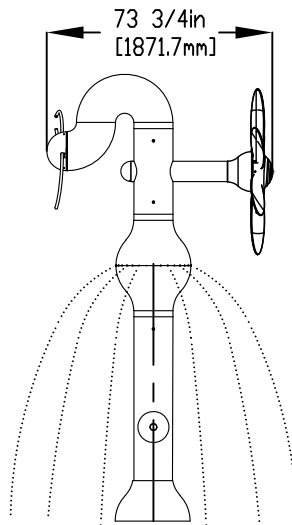
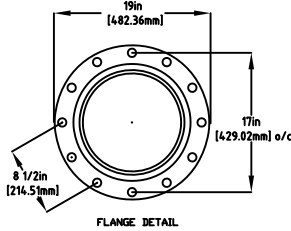
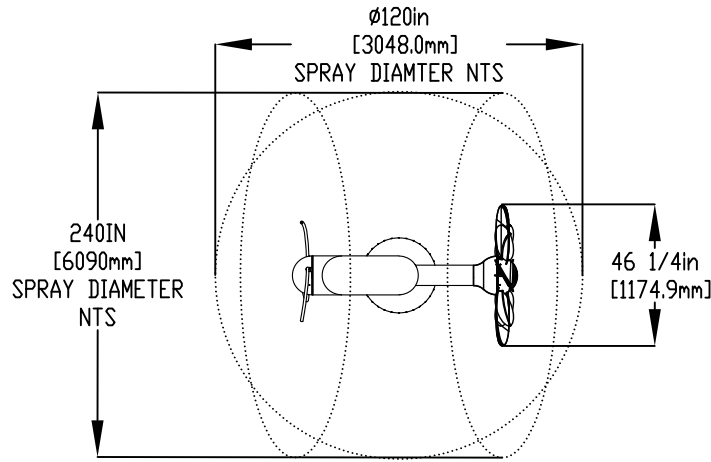

2" (50mm) FLEX HOSE PROVIDED BY EMPEX

2" (50mm) COUPLING
2" (50mm) TO 1" (25mm) REDUCER
1" (25mm) HOSEBARB W/ SS CLAMP TO BE PROVIDED BY CONTRACTOR

5/8" (16mm) X 9" (229mm) 316SS THREADED ROD C/W FENDER WASHER LOCK WASHER & NUT (X6), MINIMUM 6" (152mm) EMBEDMENT, EPOXY SET ANCHORE ADHESIVE. TO BE PROVIDED BY CONTRACTOR

- 12 - #4 @ 10" (250mm) EACH WAY
- 10 - #4 @ 10" (250mm) EACH WAY
- 8 - #4 @ 10" (250mm) EACH WAY
- 4 - #4 @ 10" (250mm) EACH SIDE

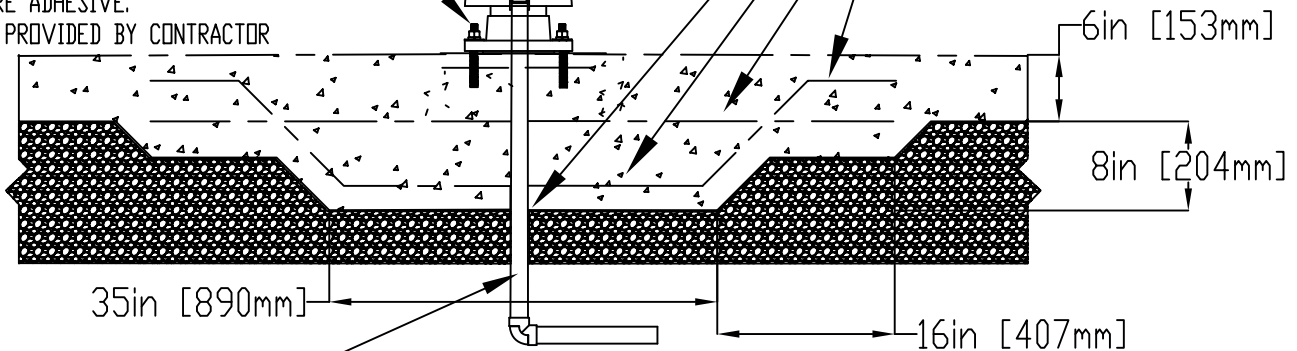

WATERFEED
2" (50mm) PVC SCH 40 PIPE EXTENDED 6" (152mm) ABOVE SLAB.

Notes: Overall dimensions of toys are approximate.
Approximate Weight: TBC

© EMPEX WATERTOYS



WATER SUPPLY
30 gpm @ 25 psi
1.89L/S @17.5m

AQUAWIZZ AERO

AE301

07/07/2022

SCALE:

Sheet
1 of 1