

1

2

3

4

NOTES:

- (1) PURGE ALL WATER SUPPLY LINES TO REMOVE SOLIDS PRIOR TO TOY INSTALLATION.
- (2) PROVIDE ELECTRICAL BOND WITH POOL REBAR.
- (3) INSTALL ALL WATER TOYS PLUMB AND LEVEL.
- (4) PROVIDE STRAINER UPSTREAM OF TOY WITH MAX 1/32" (0.8mm) PERFORATIONS.

A

A

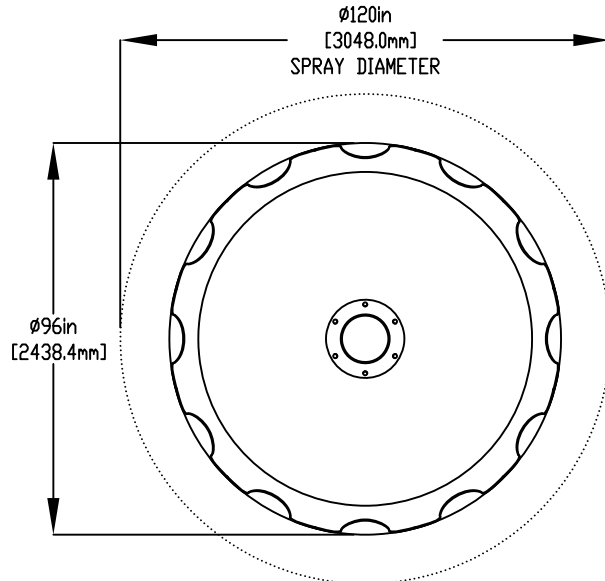

B

B

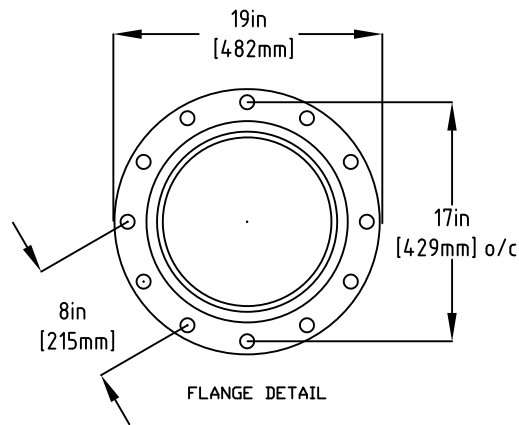

C

C

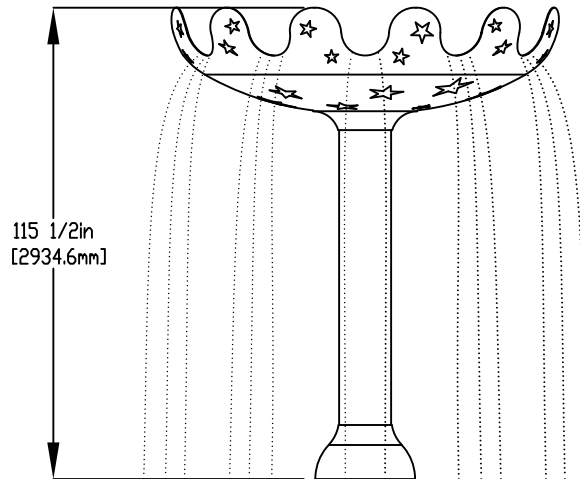

D

D

LOWER FLANGE COVER AFTER TOY IS INSTALLED.

5/8" (16mm) X 9" (230mm) 316SS
 THREADED ROD, C/W FENDER WASHER
 LOCK WASHER, & NUT. (X6) MINIMUM
 6" (152mm) EMBEDMENT, EPOXY SET
 ANCHOR ADHESIVE
 TO BE PROVIDED BY CONTRACTOR

FLOODED COLUMN -
 ENSURE LEVEL & PLUMB
 12" (304.8mm) X 1/8" (3mm) GASKET
 INSTALLED UNDER FLANGE
 TO BE PROVIDED BY EMPEX

8- #4 @ 10" (250mm) EACH WAY

4- #4 @ 10" (250mm) EACH WAY

GRANULAR BASE

WATERFEED
 4" (100mm) PVC SCH 40 PIPE
 CUT CLOSE TO ALLOW DRAINAGE

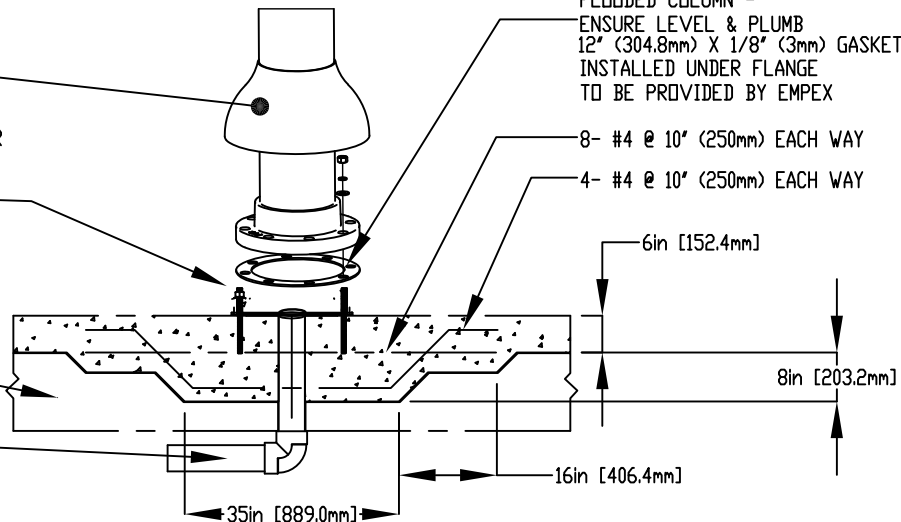

E

E

F

F



Notes: Overall dimensions of toys are approximate.

© EMPEX WATERTOYS

WATER SUPPLY

400 gpm @ 10 psi
 25.3 L/S @ 7 m

AQUAFOUNTAIN GALAXY

AG898

15/05/2020

SCALE:

Sheet 1 of 1

1

2

3

4