

NOTES:

- (1) PURGE ALL WATER SUPPLY LINES TO REMOVE SOLIDS PRIOR TO TOY INSTALLATION.
- (2) PROVIDE ELECTRICAL BOND WITH POOL REBAR.
- (3) INSTALL ALL WATER TOYS PLUMB AND LEVEL.
- (4) PROVIDE STRAINER UPSTREAM OF TOY WITH MAX 1/32" (0.8mm) PERFORATIONS.

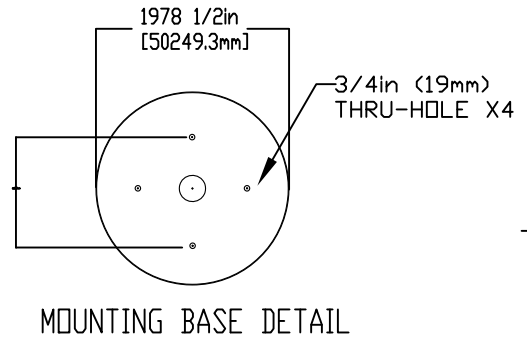
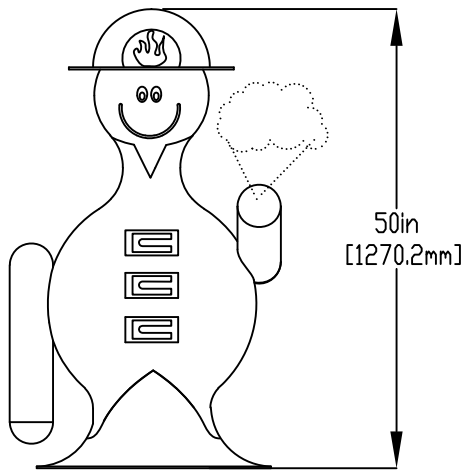
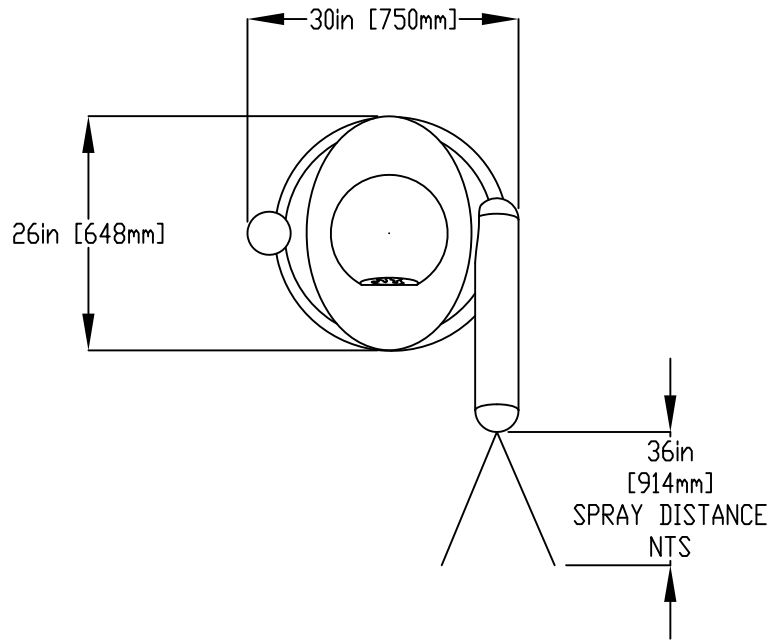

BASE INSTALL DETAILS

- 1. Bolt Base Flare to Slab
- 2. Make Plumbing Connections
- 3. Lower Toy & Bolt to base

1/2" (50mm) X 8" (203mm) 316SS THREADED ROD, C/W FENDER WASHER, LOCK WASHER, & NUT (X4). MINIMUM 6" (152mm) EMBEDMENT, EPOXY SET ANCHOR ADHESIVE TO BE PROVIDED BY CONTRACTOR

1" (25mm) FLEX HOSE PROVIDED BY EMPEX.

2" (50mm) COUPLING  
2" (50mm)-1" (25mm) REDUCER  
1" (25mm) HOSE BARB W/ SS CLAMP TO BE PROVIDED BY CONTRACTOR.

WATER FEED.  
2" (50mm) PVC SCH 40 EXTENDED 6" (152mm) ABOVE SLAB

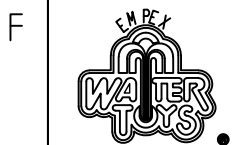
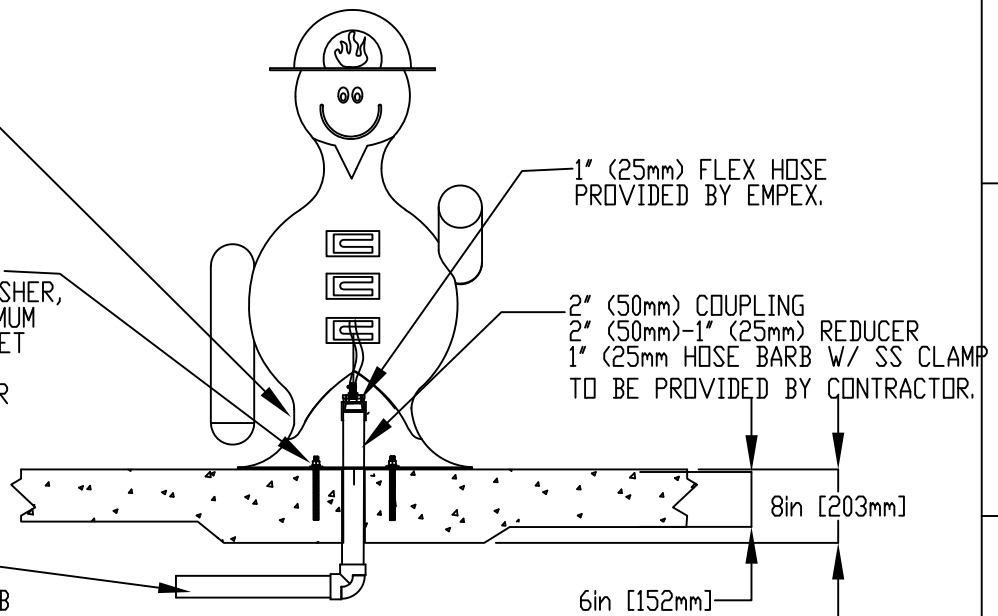

Notes: Overall dimensions of toys are approximate.

© EMPEX WATERTOYS

WATER SUPPLY

30 gpm @ 25 psi  
1.89L/S @17.5m

AQUATOT FIREMAN

AT105

18/08/22

SCALE:

Sheet  
1 of 1