

NOTES:

(1) PURGE ALL WATER SUPPLY LINES TO REMOVE SOLIDS PRIOR TO TOY INSTALLATION.

(2) PROVIDE ELECTRICAL BOND WITH POOL REBAR.

(3) INSTALL ALL WATER TOYS PLUMB AND LEVEL.

(4) PROVIDE STRAINER UPSTREAM OF TOY WITH MAX 1/32" (0.8mm) PERFORATIONS.

[1524mm]
Ø 60in
SPRAY AREA

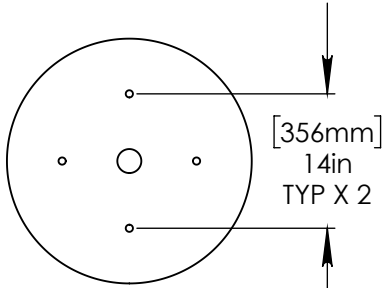
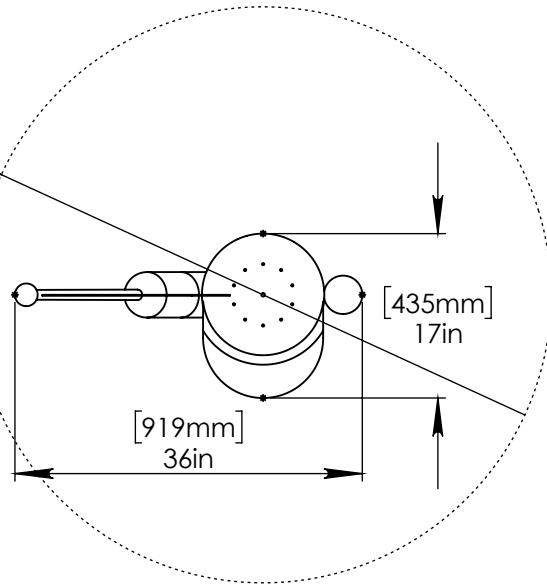

FLANGE DETAIL

LOWER FLANGE COVER AFTER TOY IS INSTALLED.

STAINLESS STEEL (316)
5/8" (16mm) THREADED ROD, WASHER,
LOCK WASHER, & NUT.
THREADED ROD LENGTH 7" (180mm)
WITH 5" (130mm) EMBEDMENT. USE
MINIMUM 6 ANCHORS.

1" (25mm) FLEX HOSE
PROVIDED BY EMPEX.

2" (50mm)-1"(25mm) FITTING
AND HOSE BARB TO BE SUPPLIED
BY CONTRACTOR.

2" (50mm) SCH 40 PVC
WATERFEED TO BE EXTENDED
8" (203mm) ABOVE SLAB.

2" (50mm) PVC SCH 40
WATER FEED.

[1794mm]
71in

[203mm]
8in

Notes: Overall dimensions of toys are approximate.

© EMPEX WATERTOYS



WATER SUPPLY
30 gpm @ 25 psi
1.89L/S @ 17.5m

AQUATOT

AT108

2/16/2017

SCALE:
1:20

Sheet
1 of 1