

NOTES:

(1) PURGE ALL WATER SUPPLY LINES TO REMOVE SOLIDS PRIOR TO TOY INSTALLATION.

(2) PROVIDE ELECTRICAL BOND WITH POOL REBAR.

(3) INSTALL ALL WATER TOYS PLUMB AND LEVEL.

(4) PROVIDE STRAINER UPSTREAM OF TOY WITH MAX 1/32" (0.8mm) PERFORATIONS.

[321mm] TRUE R13in

[3048 mm] Ø 120 in SPRAY DIAMETER NTS

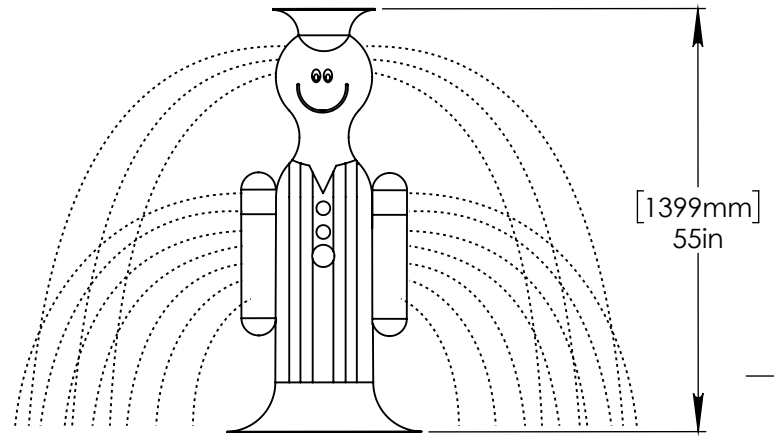
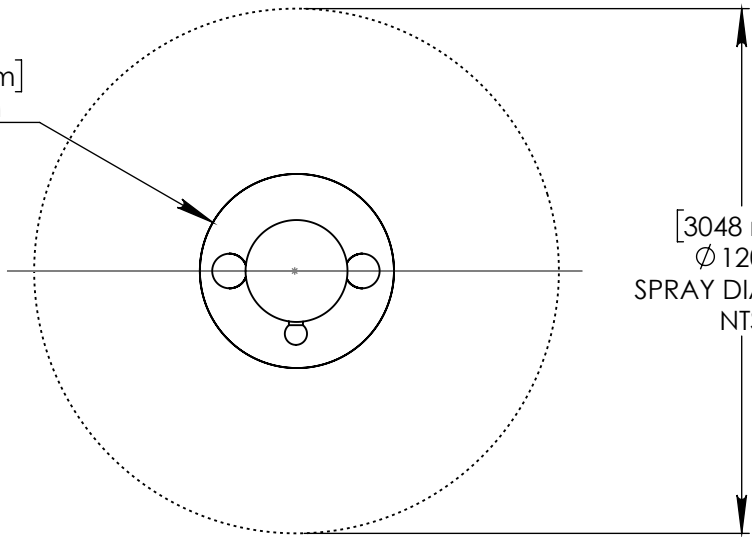
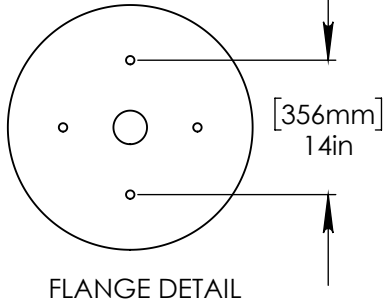

LOWER FLANGE COVER AFTER TOY IS INSTALLED.

1" (25mm) FLEX HOSE PROVIDED BY EMPEX.

2" (50mm)-1"(25mm) FITTING AND HOSE BARB TO BE SUPPLIED BY CONTRACTOR.

STAINLESS STEEL (316) 5/8" (16mm) THREADED ROD, WASHER, LOCK WASHER, & NUT. THREADED ROD LENGTH 7" (180mm) WITH 5" (130mm) EMBEDMENT. USE MINIMUM 6 ANCHORS.

2" (50mm) PVC SCH 40 WATER FEED.



Notes: Overall dimensions of toys are approximate.

© EMPEX WATERTOYS

WATER SUPPLY  
30 gpm @ 25 psi  
1.89L/S @ 17.5m

# TRAIN CONDUCTOR

**AT-113**

5/5/2017

SCALE:  
1:25

Sheet  
1 of 1