

NOTES:

(1) PURGE ALL WATER SUPPLY LINES TO REMOVE SOLIDS PRIOR TO TOY INSTALLATION.

(2) PROVIDE ELECTRICAL BOND WITH POOL REBAR.

(3) INSTALL ALL WATER TOYS PLUMB AND LEVEL.

(4) PROVIDE STRAINER UPSTREAM OF TOY WITH MAX 1#32" (0.8mm) PERFORATIONS.

[3048mm]
Ø 120in
SPRAY DIAMETER
NTS

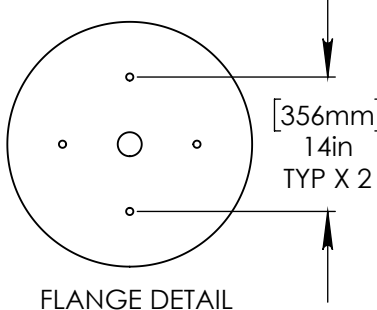
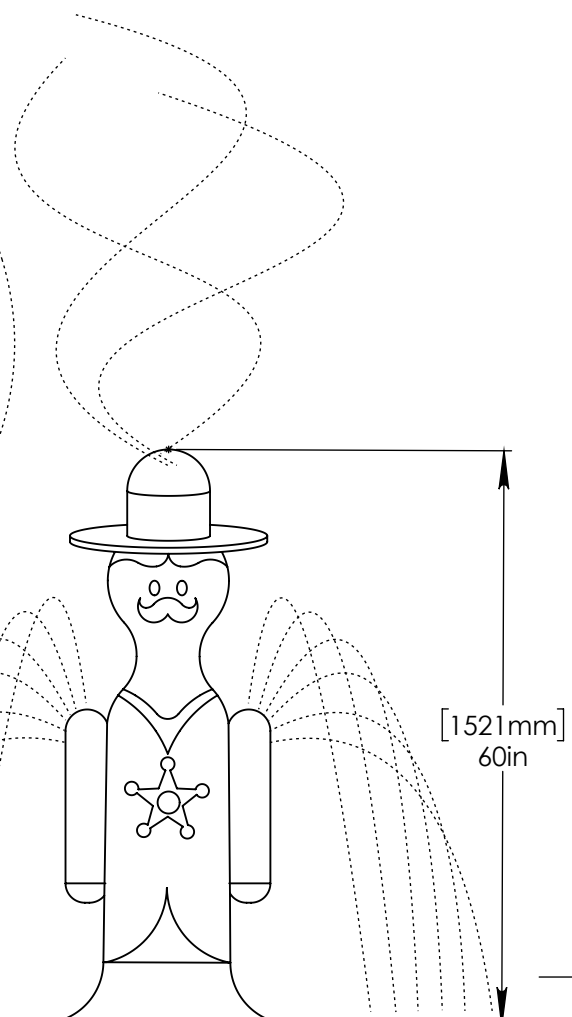
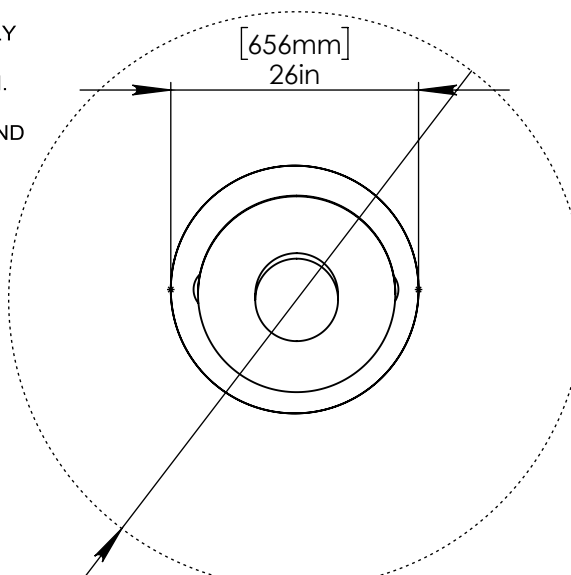

FLANGE DETAIL

LOWER FLANGE COVER AFTER TOY IS INSTALLED.

STAINLESS STEEL (316) 5/8" (16mm) THREADED ROD, WASHER, LOCK WASHER, & NUT. THREADED ROD LENGTH 7" (180mm) WITH 5" (130mm) EMBEDMENT. USE MINIMUM 6 ANCHORS.

1" (25mm) FLEX HOSE PROVIDED BY EMPEX.
2" (50mm)-1"(25mm) FITTING AND HOSE BARB TO BE SUPPLIED BY CONTRACTOR.
2" (50mm) SCH 40 PVC WATERFEED TO BE EXTENDED 8" (203mm) ABOVE SLAB.

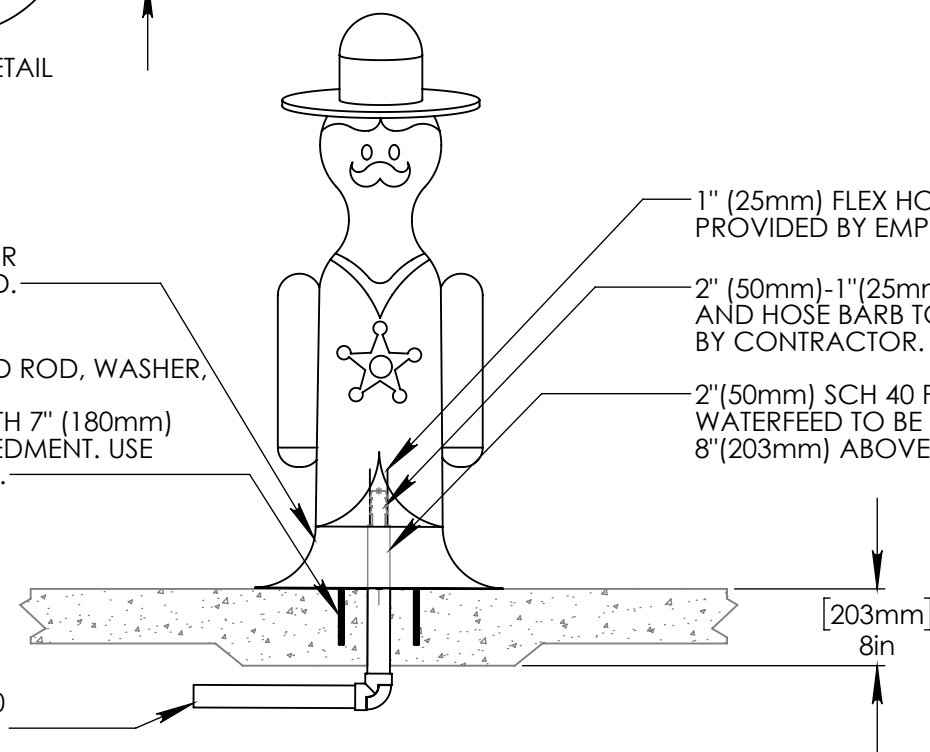

2" (50mm) PVC SCH 40 WATER FEED.

Notes: Overall dimensions of toys are approximate.

© EMPEX WATERTOYS



WATER SUPPLY
30 gpm @ 25 psi
1.89L/S @ 17.5m

AQUATOT DEPUTY

AT115

1/9/2019

SCALE:
1:20

Sheet
1 of 1