

1

2

3

4

A

A

**NOTES:**

- (1) PURGE ALL WATER SUPPLY LINES TO REMOVE SOLIDS PRIOR TO TOY INSTALLATION.
- (2) PROVIDE ELECTRICAL BOND WITH POOL REBAR.
- (3) INSTALL ALL WATER TOYS PLUMB AND LEVEL.
- (4) PROVIDE STRAINER UPSTREAM OF TOY WITH MAX 1/32" (0.8mm) PERFORATIONS.

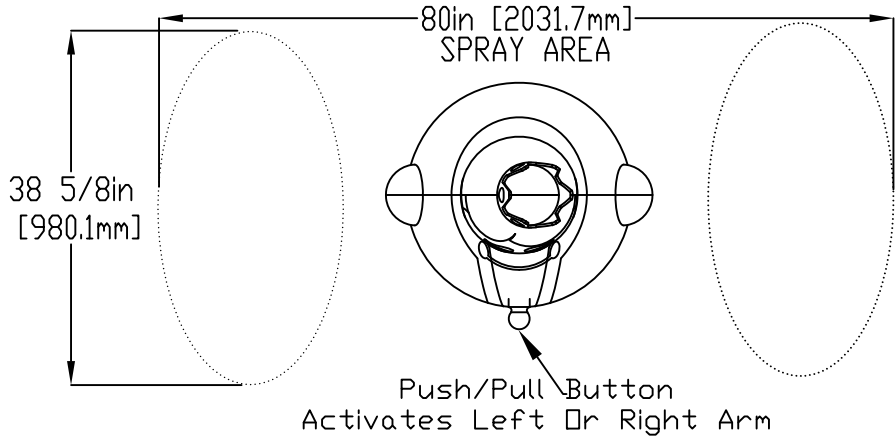

B

B

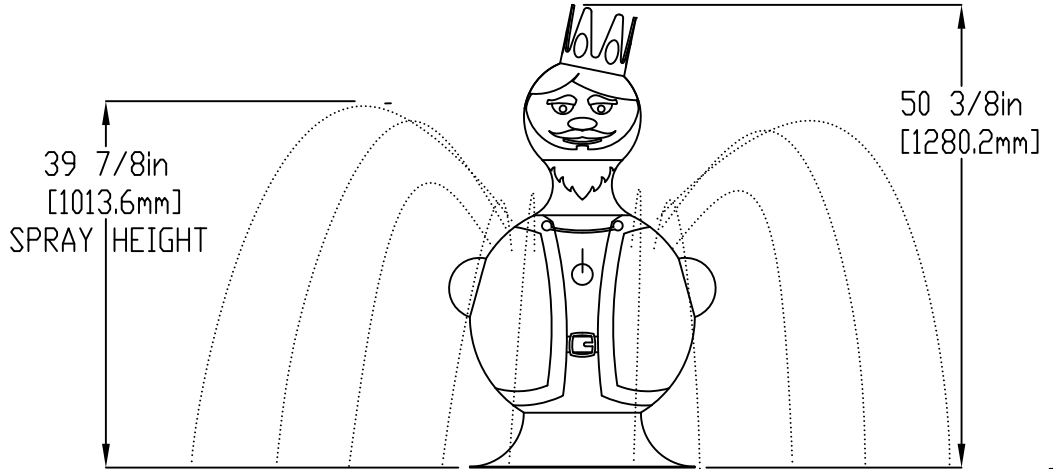

C

C

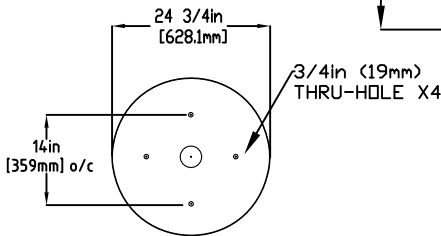

MOUNTING PLATE DETAIL

D

D

LOWER BODY OVER SLEEVE AFTER BASE IS INSTALLED.

5/8" (16mm) X 9" (229mm) 316SS THREADED ROD C/W FENDER WASHER, LOCK WASHER, & NUT (X4). MINIMUM 6" (152mm) EMBEDMENT, EPOXY SET ANCHOR ADHESIVE TO BE PROVIDED BY CONTRACTOR

1" (25mm) FLEX HOSE PROVIDED BY EMPEX.

2" (50mm) COUPLING  
 2" (50mm) -1" (25mm) REDUCER  
 1" (25mm) HOSEBARB w/SS CLAMP TO BE PROVIDED BY CONTRACTOR.

E

E

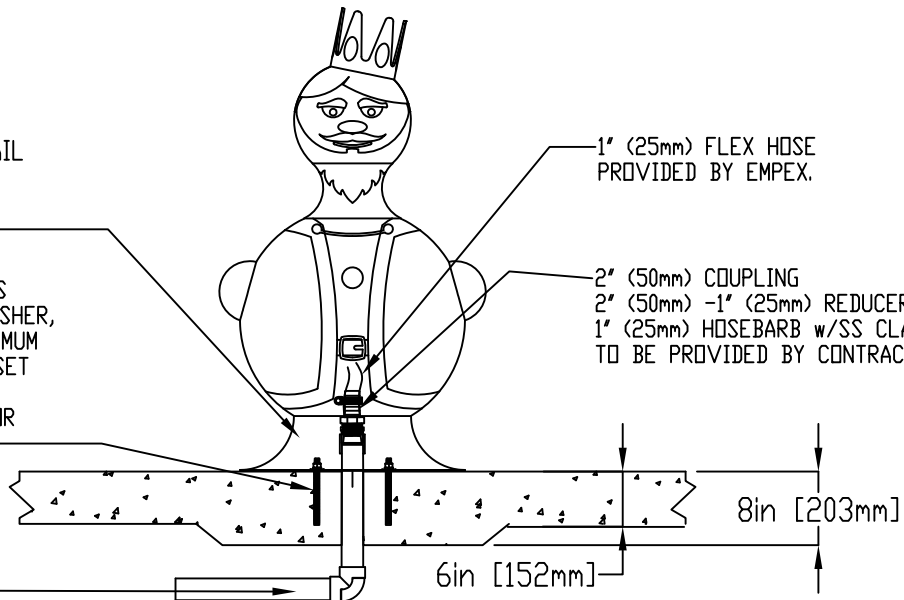

WATERFEED  
 2" (50mm) PVC SCH 40 PIPE  
 EXTENDED 6" (152mm) ABOVE SLAB

F

F



Notes: Overall dimensions of toys are approximate.

© EMPEX WATERTOYS

WATER SUPPLY

30 gpm @ 25 psi  
 1.89L/S @17.5m

AQUATOT KING

AT117

31/08/2021

SCALE:

Sheet 1 of 1

1

2

3

4