

1

2

3

4

NOTES:

- (1) PURGE ALL WATER SUPPLY LINES TO REMOVE SOLIDS PRIOR TO TOY INSTALLATION.
- (2) PROVIDE ELECTRICAL BOND WITH POOL REBAR.
- (3) INSTALL ALL WATER TOYS PLUMB AND LEVEL.
- (4) PROVIDE STRAINER UPSTREAM OF TOY WITH MAX 1/32" (0.8mm) PERFORATIONS.

A

B

C

D

E

F

A

B

C

D

E

F

ø60in  
[1524.0mm]  
SPRAY DIAMETER  
NTS

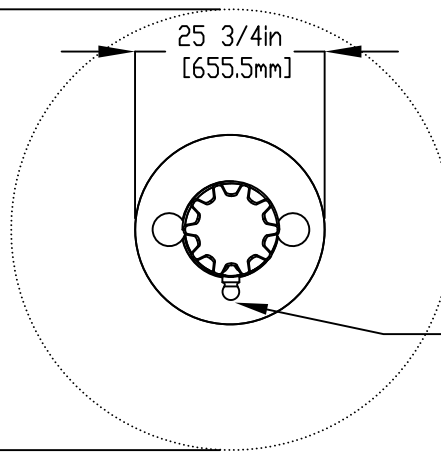

PUSH/PULL BUTTON  
ACTIVATES TOP/SIDE  
SPRAYS

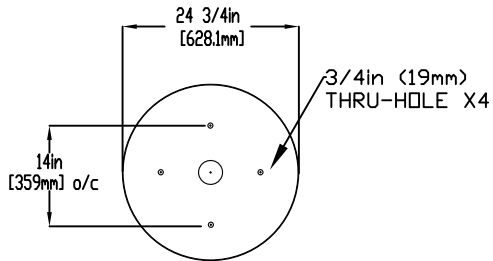

MOUNTING PLATE DETAIL

55 1/4in  
[1404.2mm]  
SPRAY HEIGHT

78 1/2in  
[1995.2mm]

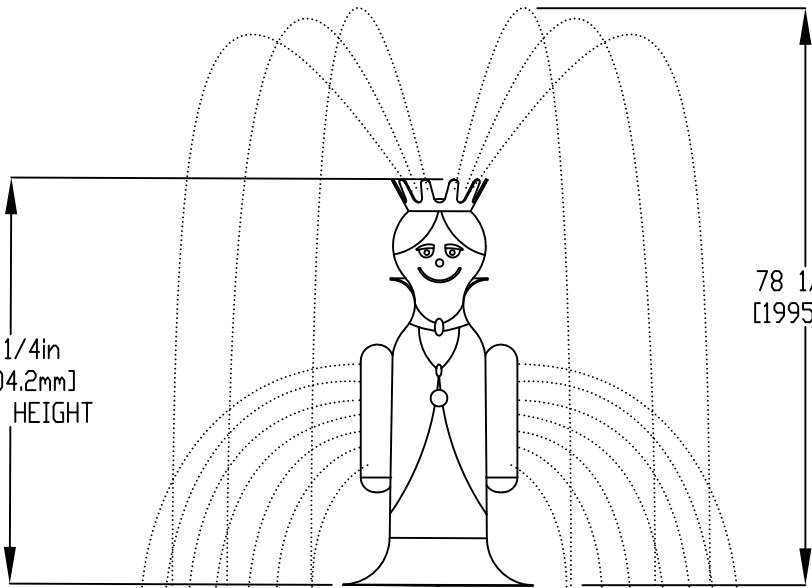

LOWER BODY OVER SLEEVE  
AFTER BASE IS INSTALLED.

1" (25mm) FLEX HOSE  
PROVIDED BY EMPEX.

2" (50mm) COUPLING  
2" (50mm) - 1" (25mm) REDUCER  
1" (25mm) HOSEBARB W/ SS CLAMP  
TO BE PROVIDED BY CONTRACTOR

5/8" (16mm) X 9" (229mm) 316SS  
THREADED ROD C/W FENDER WASHER,  
LOCK WASHER, & NUT (X4). MINIMUM  
6" (152mm) EMBEDMENT, EPOXY SET  
ANCHOR ADHESIVE  
TO BE PROVIDED BY CONTRACTOR

WATERFEED  
2" (50mm) PVC SCH 40 PIPE  
EXTENDED 6" (152mm) ABOVE SLAB

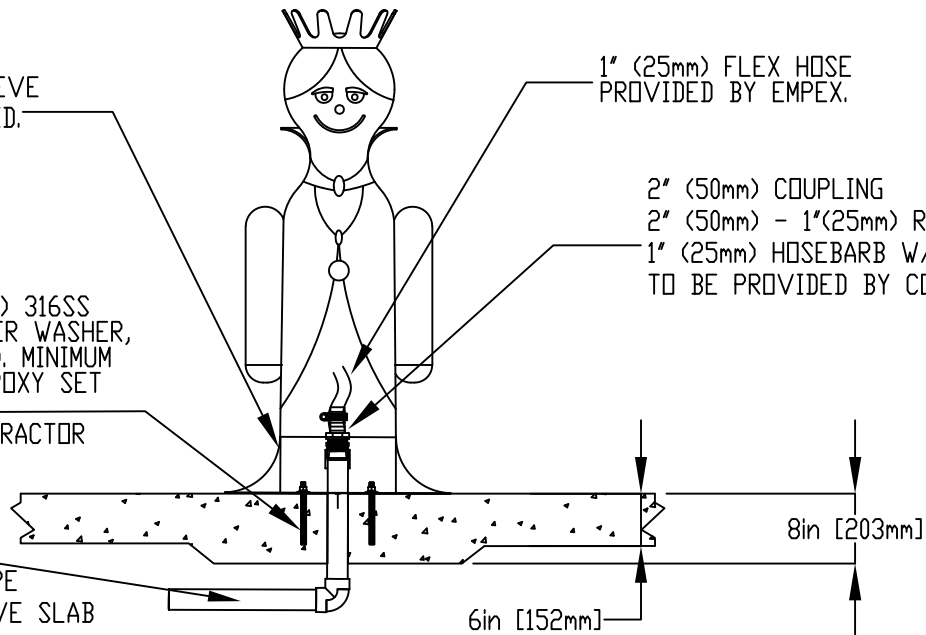

Notes: Overall dimensions of toys are approximate.

© EMPEX WATERTOYS



WATER SUPPLY  
30 gpm @ 25 psi  
1.89L/S @17.5m

AQUATOT QUEEN

AT118

01/05/2020

SCALE:

Sheet  
1 of 1

1

2

3

4