

NOTES:

- (1) PURGE ALL WATER SUPPLY LINES TO REMOVE SOLIDS PRIOR TO TOY INSTALLATION.
- (2) PROVIDE ELECTRICAL BOND WITH POOL REBAR.
- (3) INSTALL ALL WATER TOYS PLUMB AND LEVEL.
- (4) PROVIDE STRAINER UPSTREAM OF TOY WITH MAX 1/32" (0.8mm) PERFORATIONS.

A

A

B

B

C

C

D

D

E

E

F

F

120in
[3048mm]
SPRAY DIAMETER
NTS

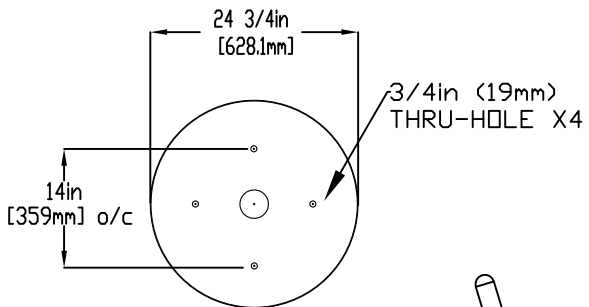
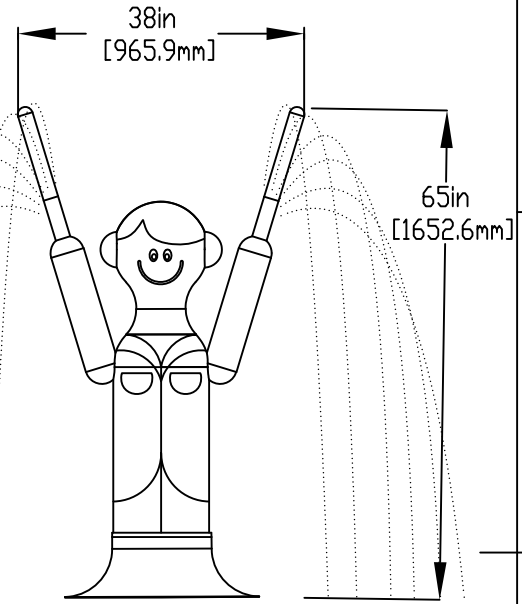
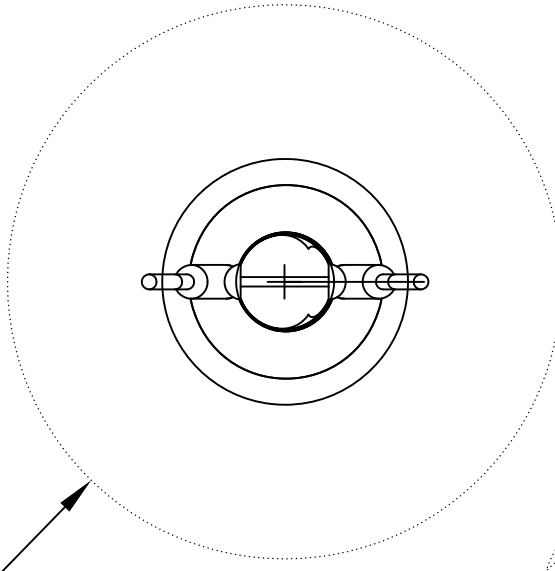

MOUNTING PLATE DETAIL

Installation Details

- 1. Bolt Flared Base to Slab
- 2. Make Plumbing Connection
- 3. Lower Toy onto Sleeve & Bolt

1/2" (13mm) X 8" (203mm) 316SS
THREADED ROD, C/W FENDER WASHER
LOCK WASHER & NUT (X4), MINIMUM
6" (152mm) EMBEDMENT, EPOXY SET
ANCHOR ADHESIVE
TO BE PROVIDED BY CONTRACTOR

1" (25mm) FLEX HOSE
PROVIDED BY EMPEX.

2" (50mm) COUPLING
2" (50mm)-1" (25mm) REDUCER
1" (25mm) HOSEBARB W/SS CLAMP
TO BE PROVIDED BY CONTRACTOR

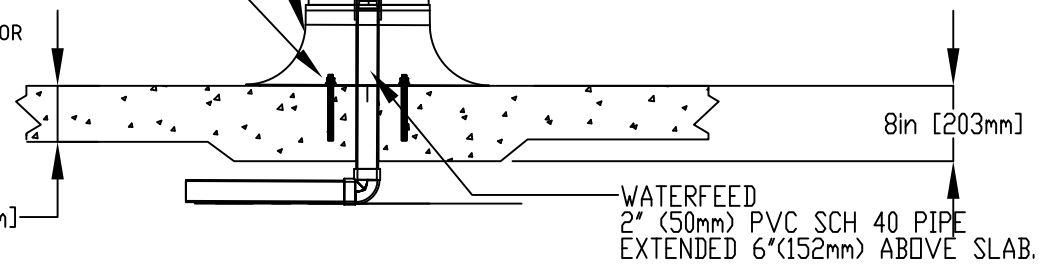

6in [152mm]

8in [203mm]

WATERFEED
2" (50mm) PVC SCH 40 PIPE
EXTENDED 6"(152mm) ABOVE SLAB.



Notes: Overall dimensions of toys are approximate.

© EMPEX WATERTOYS

WATER SUPPLY
30 gpm @ 25 psi
1.89L/S @17.5m

AQUATOT GROUND MARSHALL

AT128

8/3/2022

SCALE:

Sheet
1 of 1