

NOTES:

(1) PURGE ALL WATER SUPPLY LINES TO REMOVE SOLIDS PRIOR TO TOY INSTALLATION.

(2) PROVIDE ELECTRICAL BOND WITH POOL REBAR.

(3) INSTALL ALL WATER TOYS PLUMB AND LEVEL.

(4) PROVIDE STRAINER UPSTREAM OF TOY WITH MAX 1#32" (0.8mm) PERFORATIONS.

2" (50mm)-1" (25mm) FITTING TO BE PROVIDED BY CONTRACTOR.

STAINLESS STEEL (316) 5/8" (16mm) THREADED ROD, WASHER, LOCK WASHER, & NUT. THREADED ROD LENGTH 11" (280mm) WITH 6" (150mm) EMBEDMENT. USE MIN. 8 ANCHORS.

GRANULAR BASE
2" (50mm) PVC SCH 40 WATERFEED TO BE EXTENDED 8" (200mm) ABOVE SLAB.

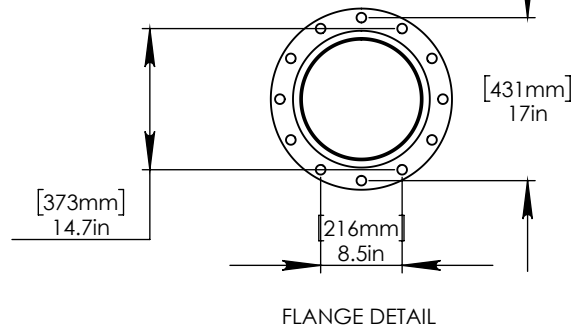

FLANGE DETAIL

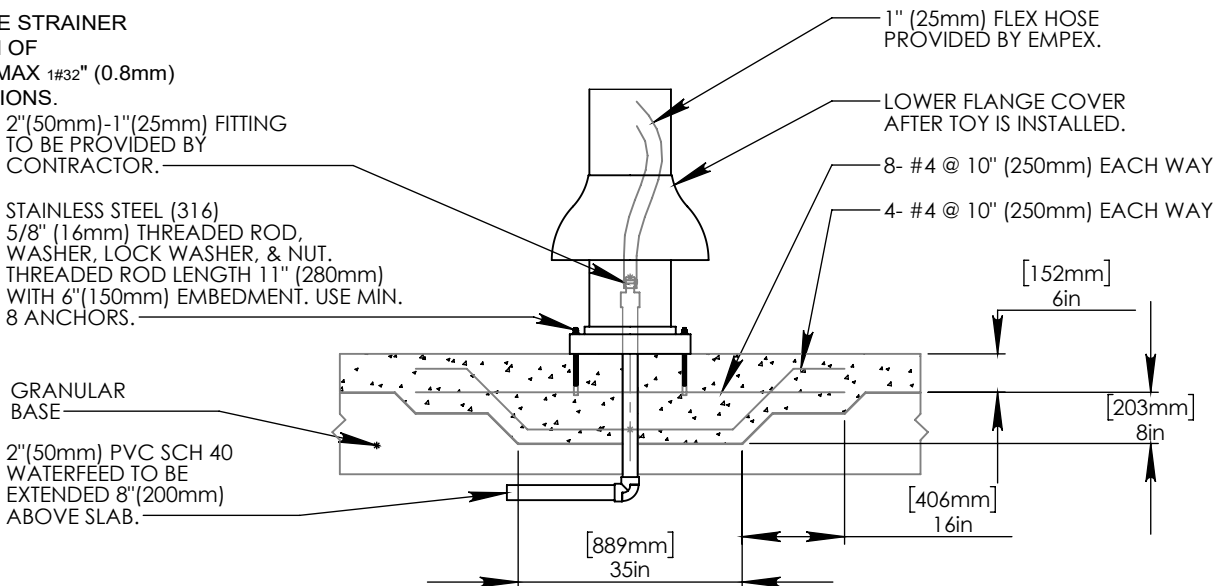

Notes: Overall dimensions of toys are approximate.

© EMPEX WATERTOYS



WATER SUPPLY

50 gpm @ 25 psi
3.15L/S @ 17.5m

TIPPIN TESSIE

B110

8/10/2016

SCALE:
1:60

Sheet
1 of 1