

NOTES:

(1) PURGE ALL WATER SUPPLY LINES TO REMOVE SOLIDS PRIOR TO TOY INSTALLATION.

(2) PROVIDE ELECTRICAL BOND WITH POOL REBAR.

(3) INSTALL ALL WATER TOYS PLUMB AND LEVEL.

(4) PROVIDE STRAINER UPSTREAM OF TOY WITH MAX 1/32" (0.8mm) PERFORATIONS.

A

A

B

B

C

C

D

D

E

E

F

F

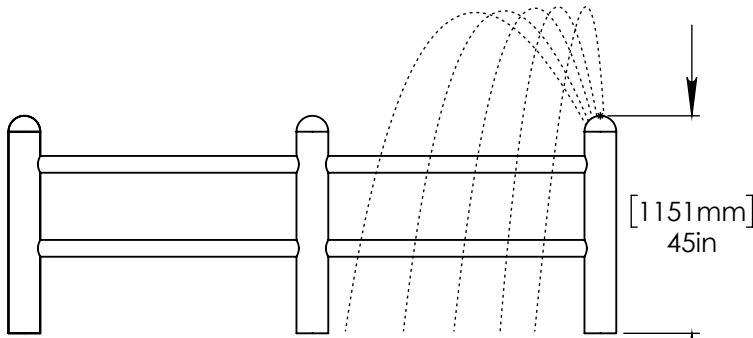
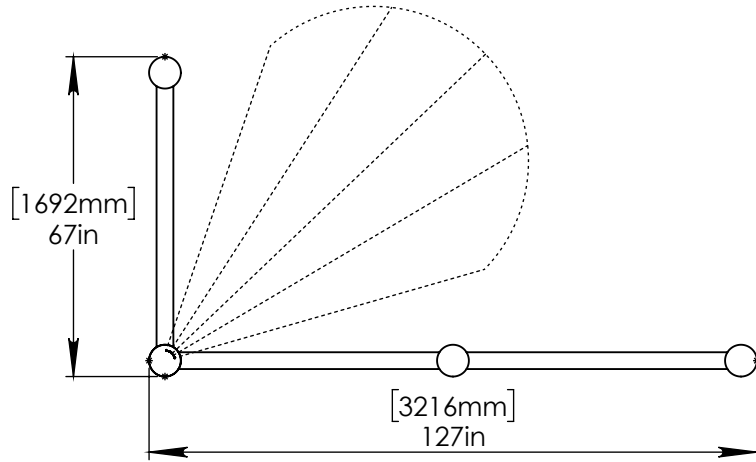

2"(50mm)-1"(25mm) FITTING AND HOSE CLAMP PROVIDED BY CONTRACTOR.

STAINLESS STEEL (316) THREADED ROD, LOCK WASHER WASHER, & NUT. THREADED ROD LENGTH 5" (125mm) WITH 4" (100mm) EMBEDMENT.

LOWER TOY OVER SLEEVE TO FINISH INSTALL

1"(25mm) FLEX HOSE PROVIDED BY EMPEX.

[114mm] 4.5in TYP X2

ANCHOR BOLT PATTERN

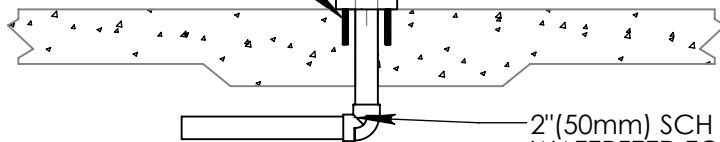

2"(50mm) SCH 40 PVC WATERFEED TO BE EXTENDED 8"(200mm) ABOVE SLAB.

Notes: Overall dimensions of toys are approximate.

© EMPEX WATERTOYS



WATER SUPPLY
30 gpm @ 25 psi
1.89L/S @ 17.5m

AQUARAILS

B205

8/12/2016

SCALE:
1:40

Sheet
1 of 1