

NOTES:

- (1) PURGE ALL WATER SUPPLY LINES TO REMOVE SOLIDS PRIOR TO TOY INSTALLATION.
- (2) PROVIDE ELECTRICAL BOND WITH POOL REBAR.
- (3) INSTALL ALL WATER TOYS PLUMB AND LEVEL.
- (4) PROVIDE STRAINER UPSTREAM OF TOY WITH MAX 1/32" (0.8mm) PERFORATIONS.

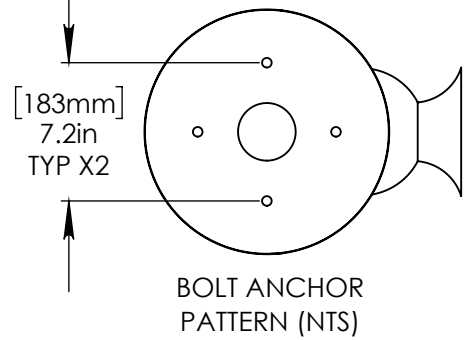
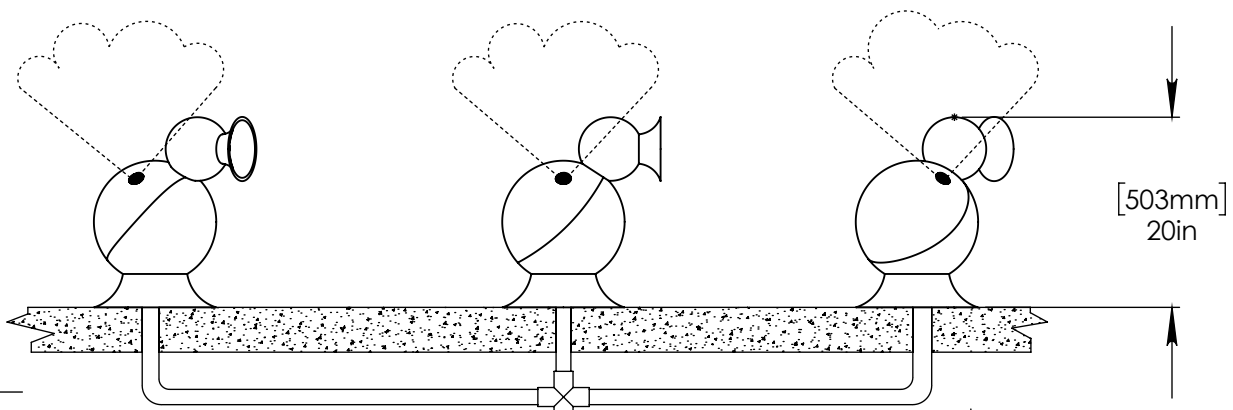
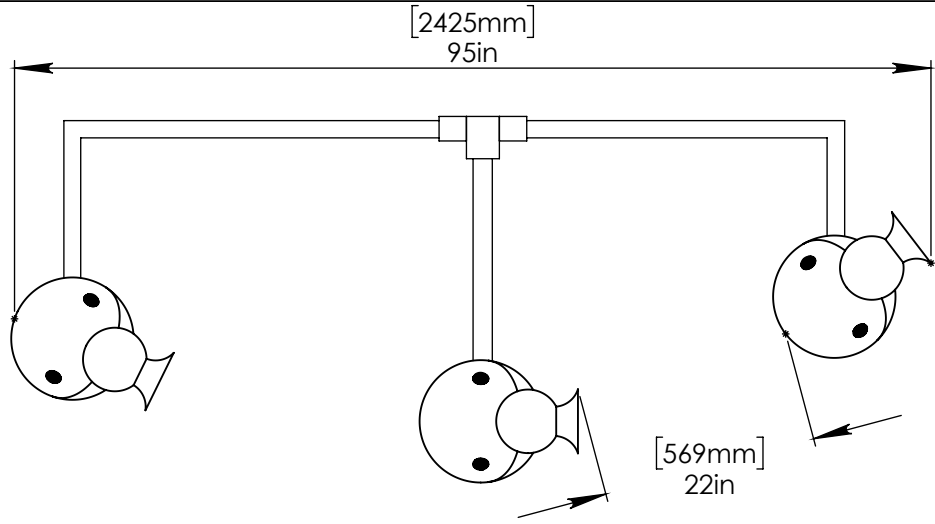

2" (50mm) TO 1" (25mm) ADAPTER TO BE SUPPLIED BY CONTRACTOR.

STAINLESS STEEL (316) 1/2" (13mm) THREADED ROD, WASHER, LOCK WASHER, & NUT. 5" LONG THREADED ROD WITH 4" (100mm) EMBEDMENT.

1" (25mm) HOSE PROVIDED BY EMPEX.

2" (50mm) SCH 40 PVC WATERFEED TO BE EXTENDED 6" (150mm) ABOVE POOL SLAB.

[203mm] 8in

Notes: Overall dimensions of toys are approximate.

© EMPEX WATERTOYS



WATER SUPPLY
30 gpm @ 25 psi (10GPM EACH)
1.89 L/S @ 17.5m (0.63L/S EACH)

AQUADUKLING TRIO

B206-3

8/15/2016

SCALE: 1:10

Sheet 1 of 1