

**NOTES:**

(1) PURGE ALL WATER SUPPLY LINES TO REMOVE SOLIDS PRIOR TO TOY INSTALLATION.

(2) PROVIDE ELECTRICAL BOND WITH POOL REBAR.

(3) INSTALL ALL WATER TOYS PLUMB AND LEVEL.

(4) PROVIDE STRAINER UPSTREAM OF TOY WITH MAX 1#32" (0.8mm) PERFORATIONS.

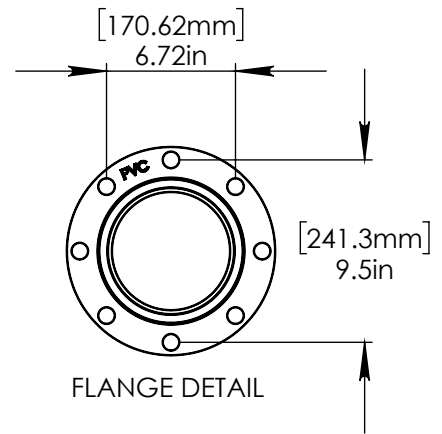
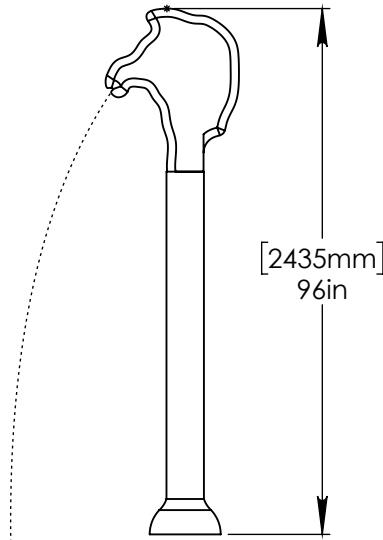
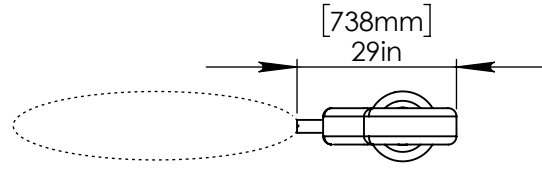

1" (25mm) FLEX HOSE PROVIDED BY EMPEX

STAINLESS STEEL (316) Ø 1/2" (13mm) THREADED ROD, WASHER, LOCK WASHER, & NUT. 7" (180mm) THREADED ROD LENGTH WITH 5" (120mm) EMBEDMENT. INSTALL MINIMUM 5 ANCHORS.

LOWER FLANGE COVER AFTER INSTALL.

2" (50mm) TO 1" (25mm) REDUCER TO BE PROVIDED BY CONTRACTOR.

2" (50mm) PVC SCH 40 WATER FEED EXTENDED 6" (150mm) ABOVE SLAB.

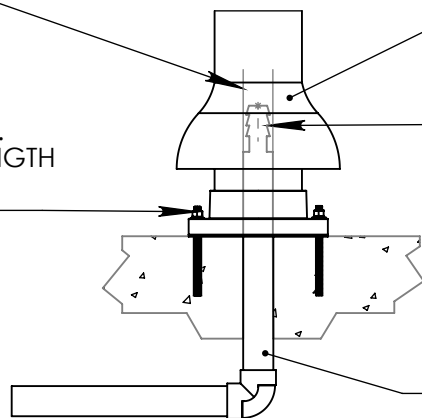

Notes: Overall dimensions of toys are approximate.

© EMPEX WATERTOYS



**WATER SUPPLY**  
10 gpm @ 25 psi  
0.63 L/S @ 17.5m

# AQUASTEED

**B207S**

8/12/2016

SCALE:  
1:35

Sheet  
1 of 1