

NOTES:

(1) PURGE ALL WATER SUPPLY LINES TO REMOVE SOLIDS PRIOR TO TOY INSTALLATION.

(2) PROVIDE ELECTRICAL BOND WITH POOL REBAR.

(3) INSTALL ALL WATER TOYS PLUMB AND LEVEL.

(4) PROVIDE STRAINER UPSTREAM OF TOY WITH MAX 1/32" (0.8mm) PERFORATIONS.

[17479mm]
688in

[12593mm]
496in

[7200mm]
283in

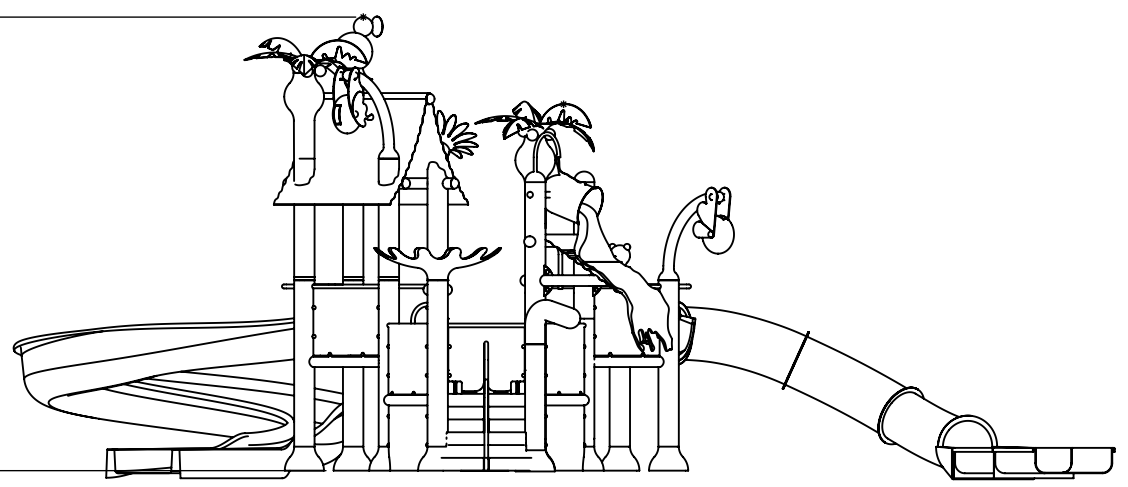
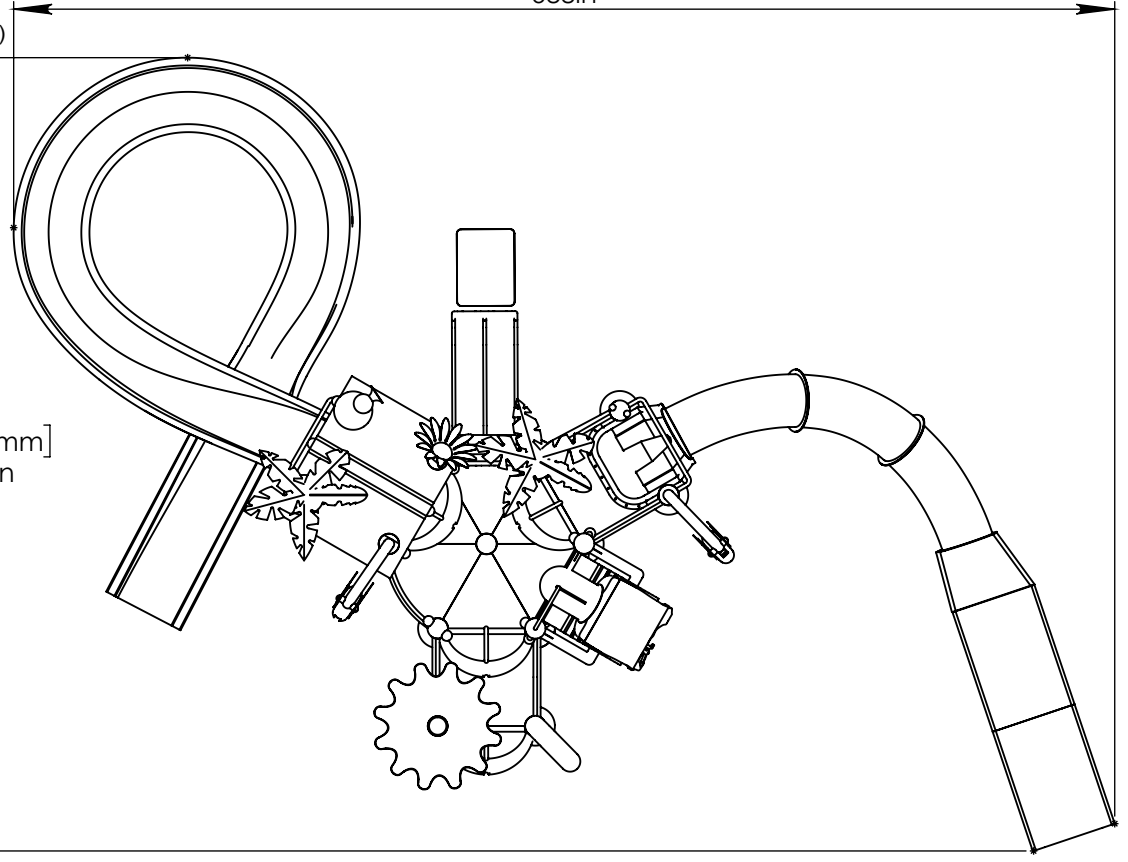

Notes: Overall dimensions of toys are approximate.

© EMPEX WATERTOYS

WATER SUPPLY
990 gpm @ 25 psi
62.5L/S @17.5m

AQUADEK

C610-TR-2SR

1/31/2017

SCALE:
1:120

Sheet
1 of 3

MANIFOLD A

HEADER PROVIDED BY EMPEX

2" (150mm) VALVE:
 (3) FIBREGLASS SLIDE
 (1) AQUADUNKER

1" (100mm) VALVE:
 (1) AQUAPALM
 (1) FROG FINIAL
 (1) AQUAFLO
 (1) AQUAGATOR

0.5" (50mm) VALVE:
 (2) AQUADUNKS

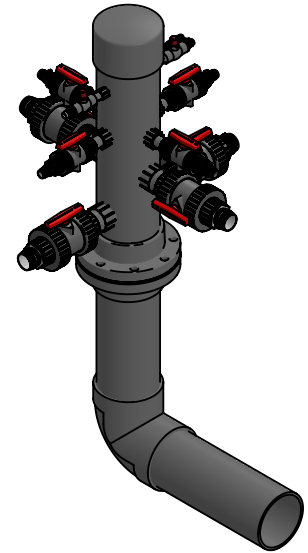

A

A

B

B

C

C

6" (150mm)
 FLANGE NOT
 PROVIDED
 BY EMPEX

POOL SLAB

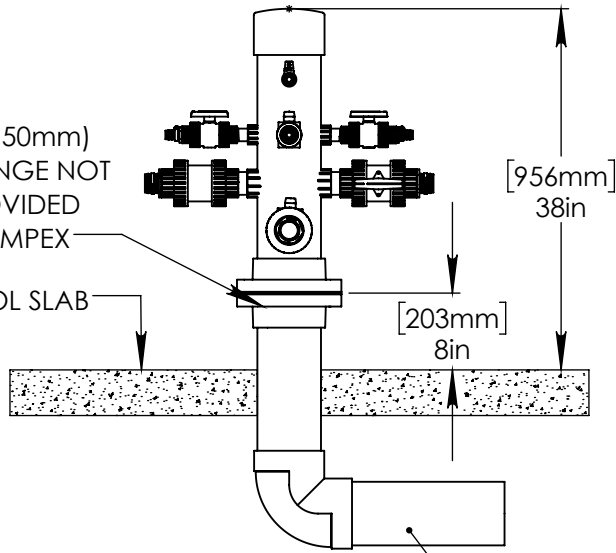

6" (150mm) PVC SCH 40
 WATERFEED

MANIFOLD B

HEADER PROVIDED BY EMPEX

2" (150mm) VALVE:
 (3) FIBREGLASS SLIDE
 (3) AQUAFOLO

1.5" (100mm) VALVE:
 (2) AQUACURTAINS
 (1) AQUADUK
 (1) MONKEY FINIAL
 (1) AQUAPALM

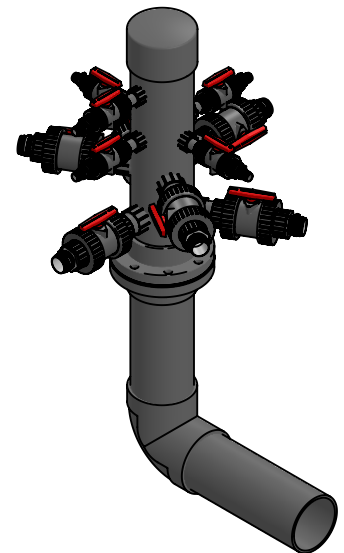

D

D

E

E

6" (150mm)
 FLANGE NOT
 PROVIDED
 BY EMPEX

POOL SLAB

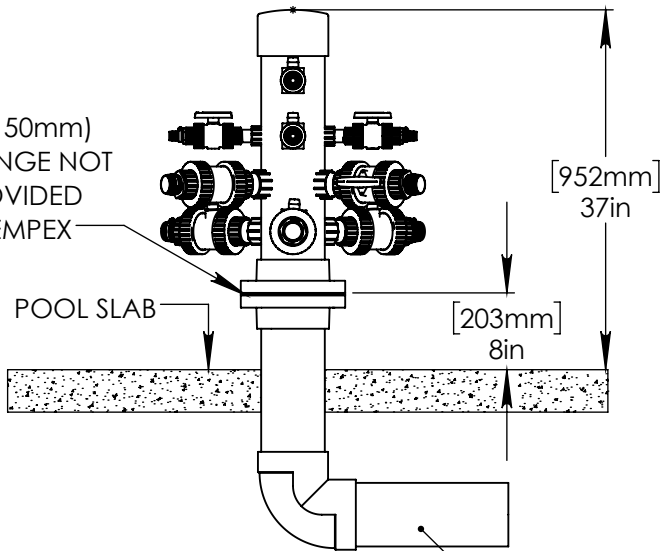

6" (150mm) PVC SCH 40
 WATERFEED

F

F



Notes: Overall dimensions of toys are approximate.

© EMPEX WATERTOYS

WATER SUPPLY
 990 gpm @ 25 psi
 62.5L/S @ 17.5m

AQUADEK

C610-TR-2SR

1/31/2017

SCALE:
1:20

Sheet
2 of 3

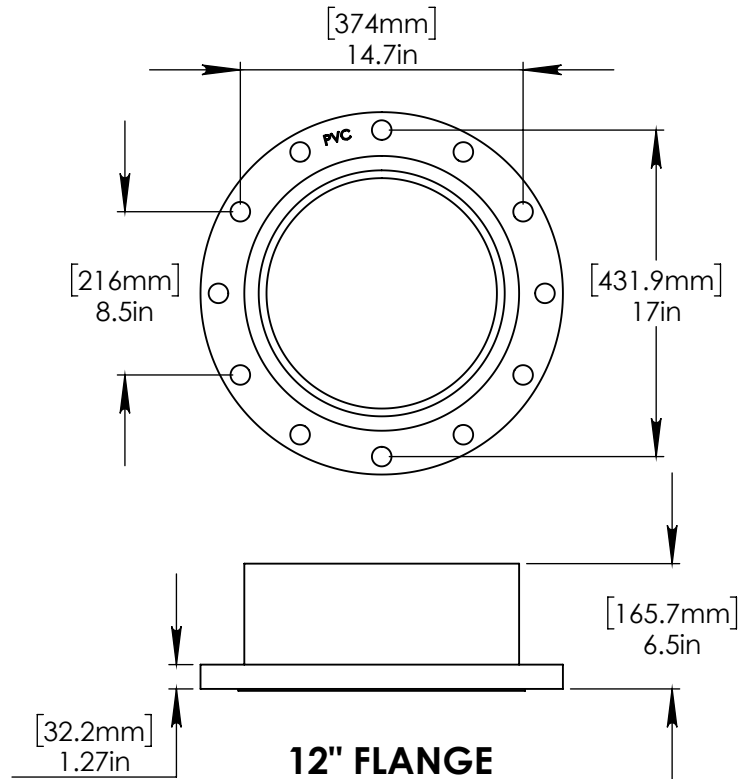
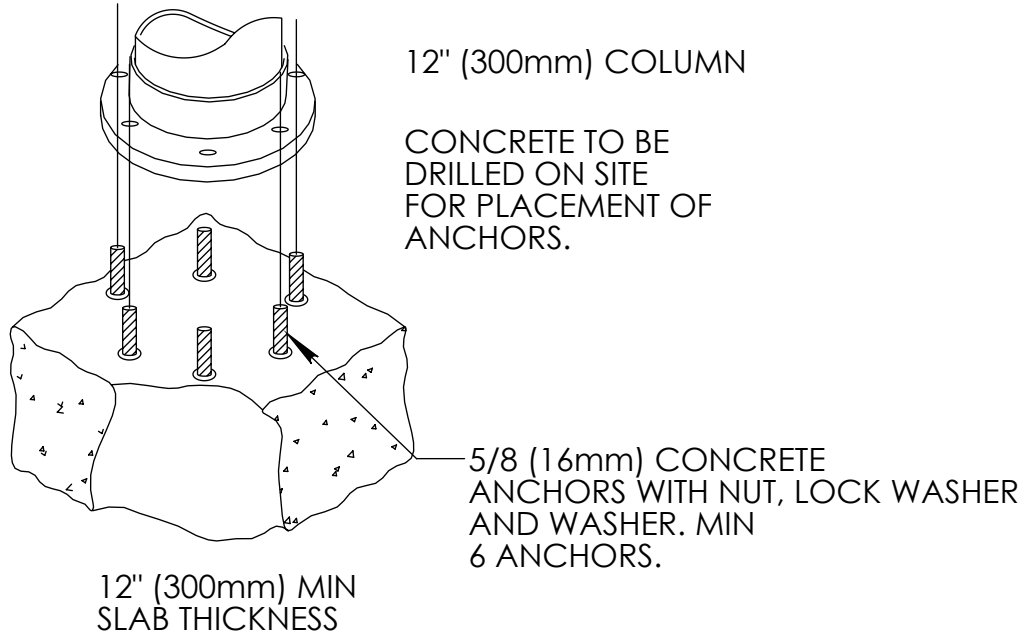

Notes: Overall dimensions of toys are approximate.

© EMPEX WATERTOYS

WATER SUPPLY
990 gpm @ 25 psi
62.5L/S @ 17.5m

AQUADEK

C610-TR-2SR

1/31/2017

SCALE:
1:10

Sheet
3 of 3