

NOTES:

- (1) PURGE ALL WATER SUPPLY LINES TO REMOVE SOLIDS PRIOR TO TOY INSTALLATION.
- (2) PROVIDE ELECTRICAL BOND WITH POOL REBAR.
- (3) INSTALL ALL WATER TOYS PLUMB AND LEVEL.
- (4) PROVIDE STRAINER UPSTREAM OF TOY WITH MAX 1#32" (0.8mm) PERFORATIONS.

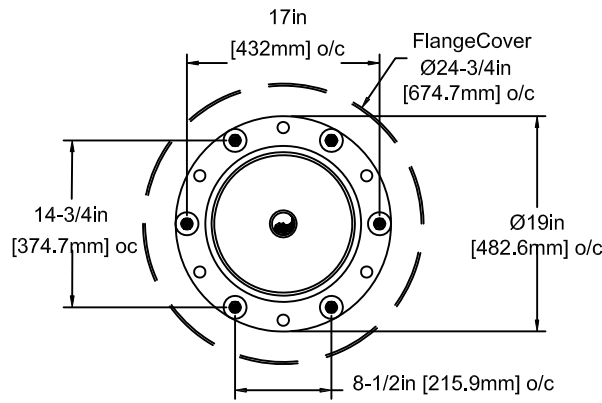

FLANGE DETAIL

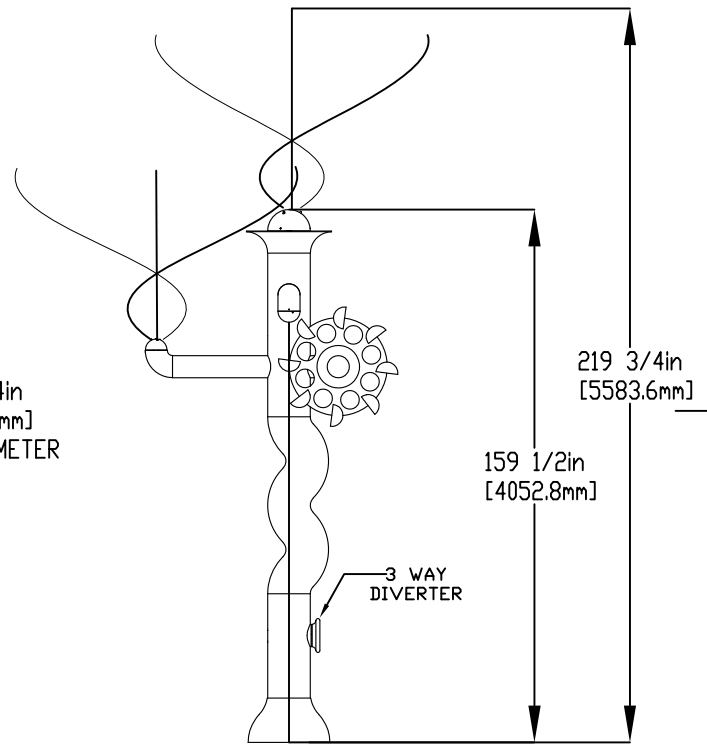
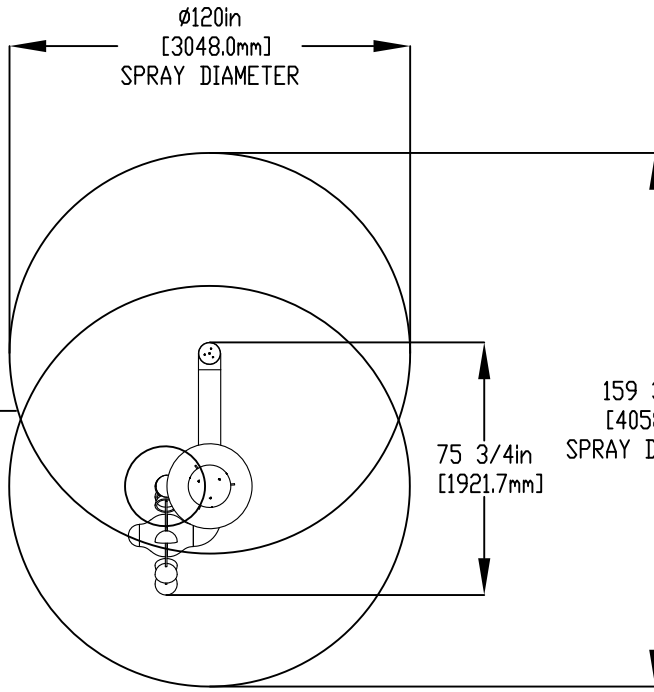

LOWER FLANGE COVER AFTER TOY IS INSTALLED.

STAINLESS STEEL (316)
 5/8" (16mm) THREADED ROD, WASHER,
 LOCK WASHER, & NUT.
 THREADED ROD LENGTH 9" (230mm)
 WITH 6" (150mm) EMBEDMENT. USE
 MINIMUM 6 ANCHORS. TO BE
 PROVIDED BY CONTRACTOR

2" (50mm) SCH 40 PVC
 WATERFEED TO BE EXTENDED
 8" (200mm) ABOVE SLAB.

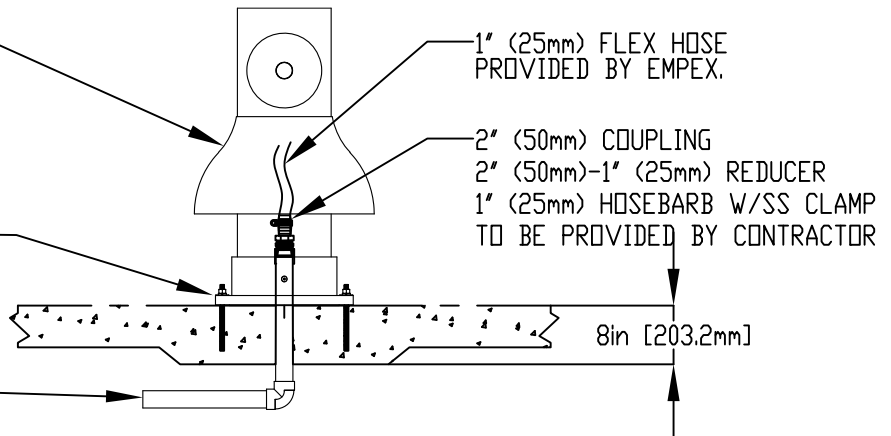

Notes: Overall dimensions of toys are approximate.
 Approximate Weight: 202lbs / 91.8kgs

© EMPEX WATERTOYS

WATER SUPPLY

30 gpm @ 25 psi
 1.89L/S @17.5m

AQUANODDLE

K302

01/05/2020

SCALE:

Sheet 1 of 1