

NOTES:

(1) PURGE ALL WATER SUPPLY LINES TO REMOVE SOLIDS PRIOR TO TOY INSTALLATION.

(2) PROVIDE ELECTRICAL BOND WITH POOL REBAR.

(3) INSTALL ALL WATER TOYS PLUMB AND LEVEL.

(4) PROVIDE STRAINER UPSTREAM OF TOY WITH MAX 1/32" (0.8mm) PERFORATIONS.

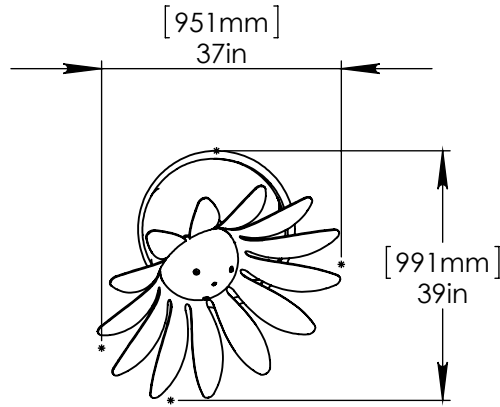

120" (3045mm) SPRAY DISTANCE

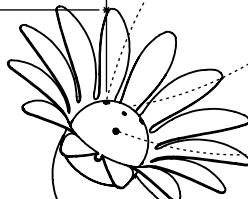

[2842mm]  
112in

[214mm]  
8.4in

[429mm]  
16.9in

[371mm]  
14.6in

FLANGE DETAIL

1" (25mm) HOSE SUPPLIED BY EMPEX

2" (50mm) TO 1" (25mm) REDUCER TO BE PROVIDED BY CONTRACTOR.

STAINLESS STEEL (316) 5/8" (16mm) THREADED ROD, WASHER, LOCK WASHER, & NUT. 9" (230mm) THREADED ROD LENGTH WITH 6" (150mm) EMBEDMENT. MINIMUM 6 ANCHORS.

2" (50mm) PVC SCH 40 WATERFEED TO BE EXTENDED 8" (200mm) ABOVE SLAB.

[203mm]  
8in

Notes: Overall dimensions of toys are approximate.

© EMPEX WATERTOYS



WATER SUPPLY

30 gpm @ 25 psi  
1.89L/S @ 17.5m

AQUAFLO DAISY

K402

11/4/2014

SCALE:  
1:30

Sheet  
1 of 1