

1

2

3

4

NOTES:

(1) PURGE ALL WATER SUPPLY LINES TO REMOVE SOLIDS PRIOR TO TOY INSTALLATION.

(2) PROVIDE ELECTRICAL BOND WITH POOL REBAR.

(3) INSTALL ALL WATER TOYS PLUMB AND LEVEL.

(4) PROVIDE STRAINER UPSTREAM OF TOY WITH MAX 1/32" (0.8mm) PERFORATIONS.

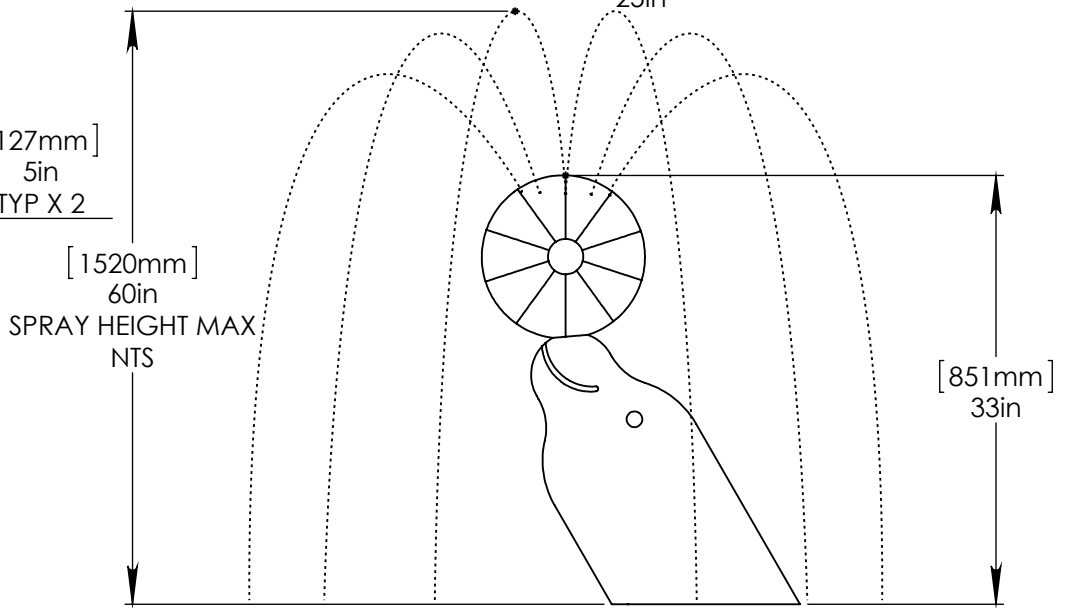
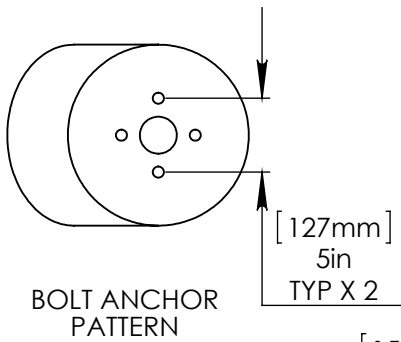
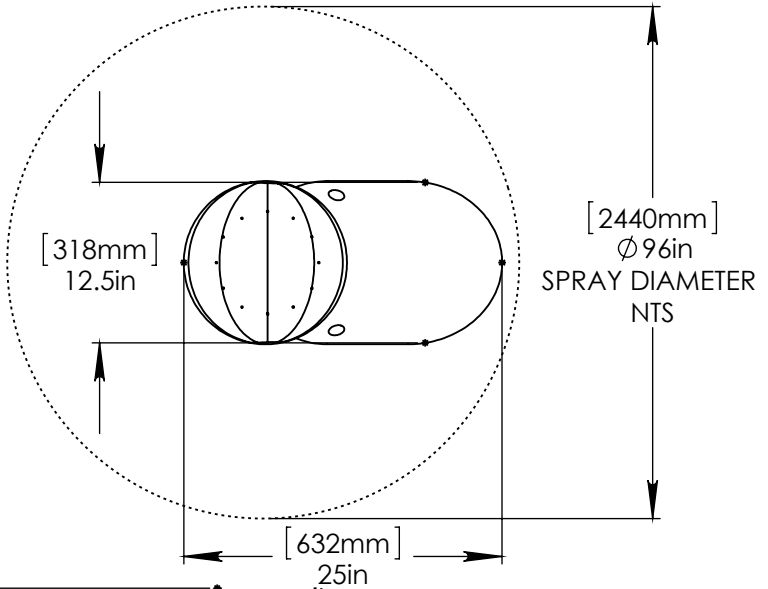

STAINLESS STEEL (316)  
THREADED ROD, LOCK WASHER  
WASHER, & NUT.  
THREADED ROD LENGTH 7" (180mm)  
WITH 6" (150mm) EMBEDMENT.

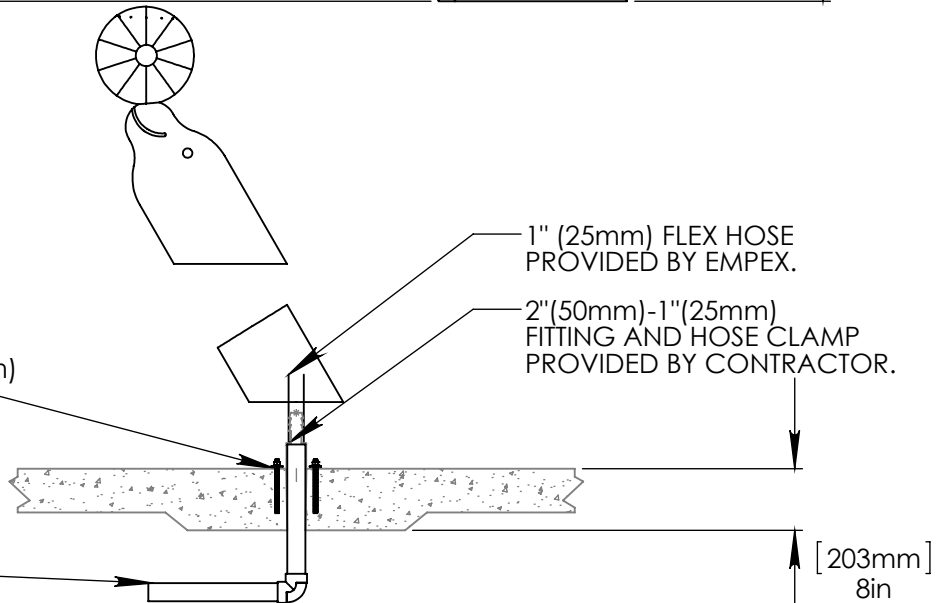

Notes: Overall dimensions of toys are approximate.

© EMPEX WATERTOYS



WATER SUPPLY  
30 gpm @ 25 psi  
1.89L/S @ 17.5m

# AQUASEAL

M505

5/12/2015

SCALE:  
1:15

Sheet  
1 of 1

1

2

3

4