

NOTES:

(1) PURGE ALL WATER SUPPLY LINES TO REMOVE SOLIDS PRIOR TO TOY INSTALLATION.

(2) PROVIDE ELECTRICAL BOND WITH POOL REBAR.

(3) INSTALL ALL WATER TOYS PLUMB AND LEVEL.

(4) PROVIDE STRAINER UPSTREAM OF TOY WITH MAX 1/32" (0.8mm) PERFORATIONS.

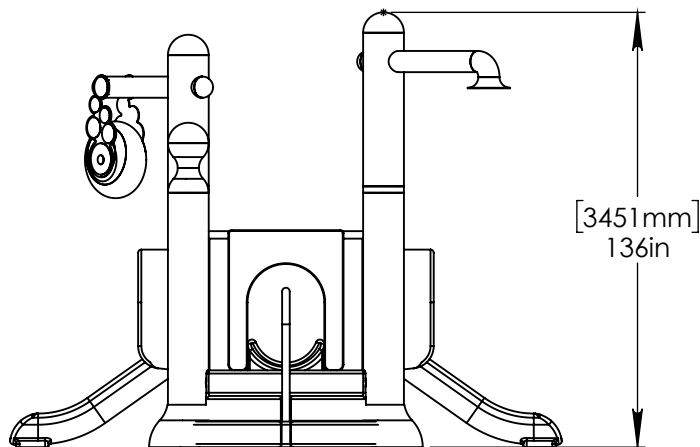
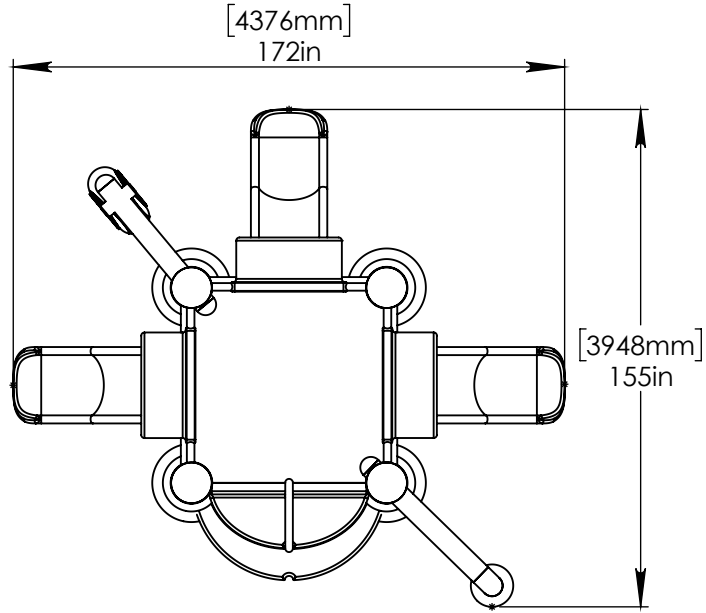

Notes: Overall dimensions of toys are approximate.

© EMPEX WATERTOYS

WATER SUPPLY  
 100 gpm @ 25 psi  
 6.3 L/S @17.5m

# AQUADEK

**T210-3S**

7/22/2016

SCALE:  
1:60

Sheet  
1 of 2

HEADER PROVIDED BY EMPEX

(3) 1" (25mm) VALVES: AQUASHOWER  
(2) FINIALS

(1) 1/2" (13mm) VALVE: AQUADUNK

4"-6" (100mm-150mm) FLANGE NOT PROVIDED BY EMPEX.

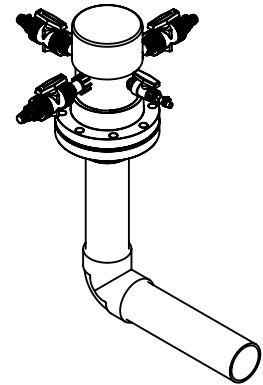

POOL SLAB

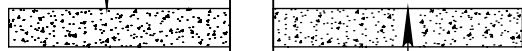

[524mm] 21in

[203mm] 8in

4" (100mm) PVC SCH 40 WATERFEED.

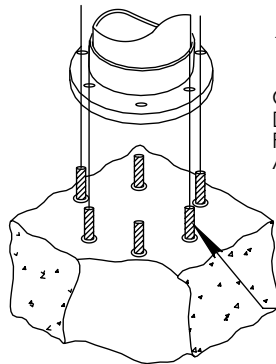

12" (300mm) COLUMN

CONCRETE TO BE DRILLED ON SITE FOR PLACEMENT OF ANCHORS.

5/8 (16mm) CONCRETE ANCHORS WITH NUT, LOCK WASHER AND WASHER. MIN 6 ANCHORS.

12" (300mm) MIN SLAB THICKNESS

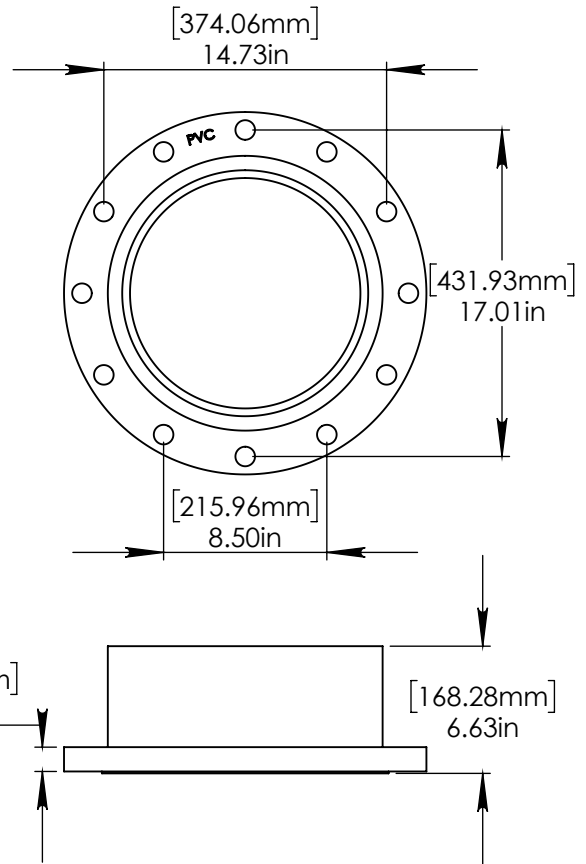

Notes: Overall dimensions of toys are approximate.

© EMPEX WATERTOYS

WATER SUPPLY  
100 gpm @ 25 psi  
6.3 L/S @17.5m

**AQUADEK**

**T210-3S**

7/22/2016

SCALE:  
1:20

Sheet  
2 of 2