

NOTES:

(1) PURGE ALL WATER SUPPLY LINES TO REMOVE SOLIDS PRIOR TO TOY INSTALLATION.

(2) PROVIDE ELECTRICAL BOND WITH POOL REBAR.

(3) INSTALL ALL WATER TOYS PLUMB AND LEVEL.

(4) PROVIDE STRAINER UPSTREAM OF TOY WITH MAX 1#32" (0.8mm) PERFORATIONS.

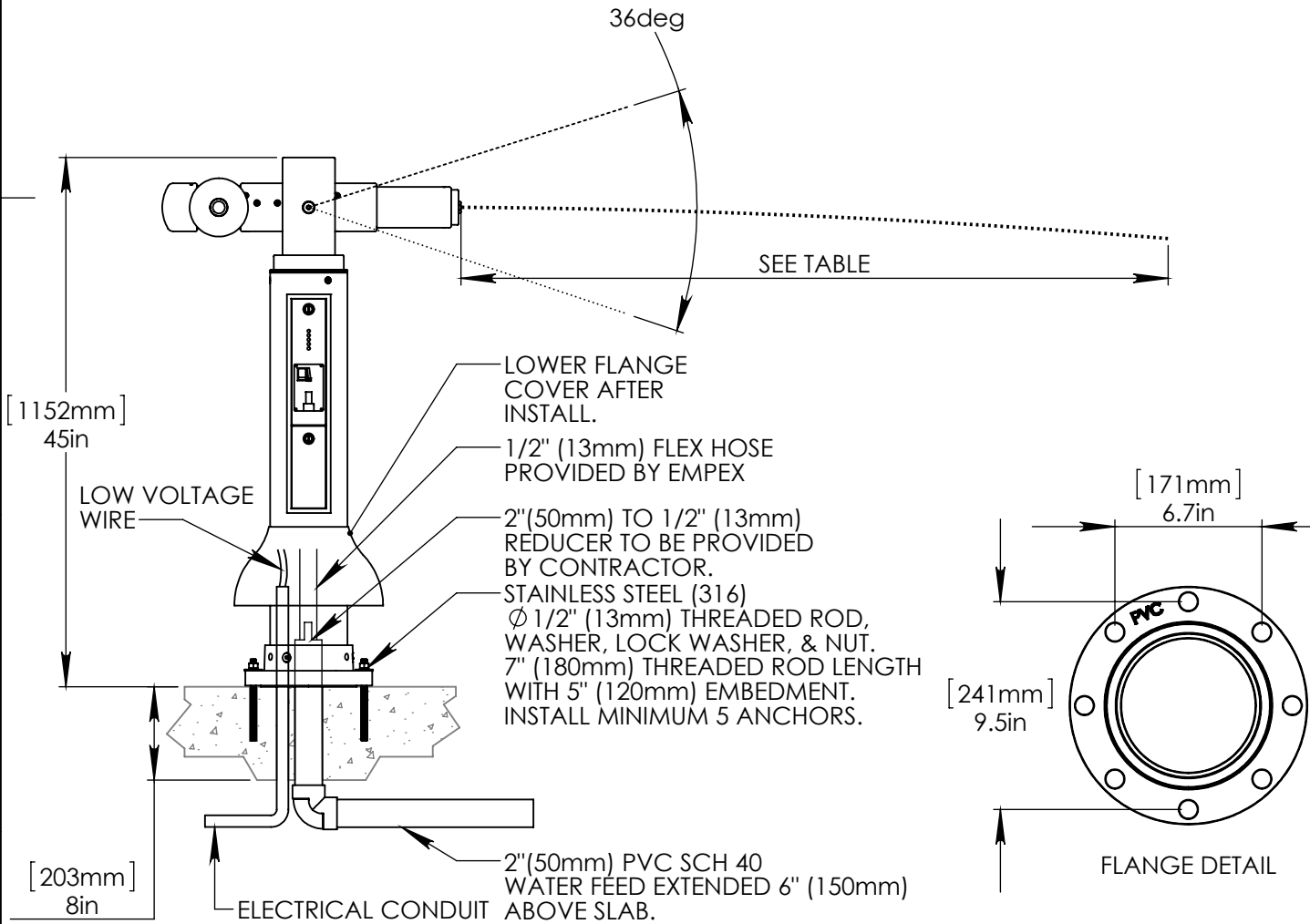
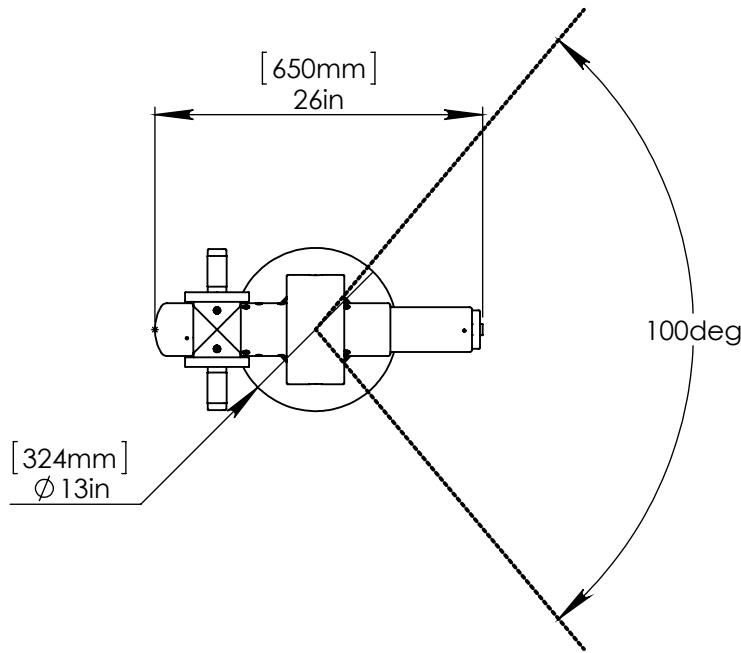

Notes: Overall dimensions of toys are approximate.

© EMPEX WATERTOYS

WATER SUPPLY					
WATER PRESSURE	FLOW GPM	L/S	DISTANCE		
10 PSI	7m	1.0	0.06	8FT	2m
20 PSI	14m	1.5	0.09	20FT	6m
30 PSI	21m	2.0	0.12	25FT	8m

WATER SHOOTER

T402-C

3/19/2015

SCALE: 1:15

Sheet 1 of 1