

NOTES:

(1) PURGE ALL WATER SUPPLY LINES TO REMOVE SOLIDS PRIOR TO TOY INSTALLATION.

(2) PROVIDE ELECTRICAL BOND WITH POOL REBAR.

(3) INSTALL ALL WATER TOYS PLUMB AND LEVEL.

(4) PROVIDE STRAINER UPSTREAM OF TOY WITH MAX 1/32" (0.8mm) PERFORATIONS.

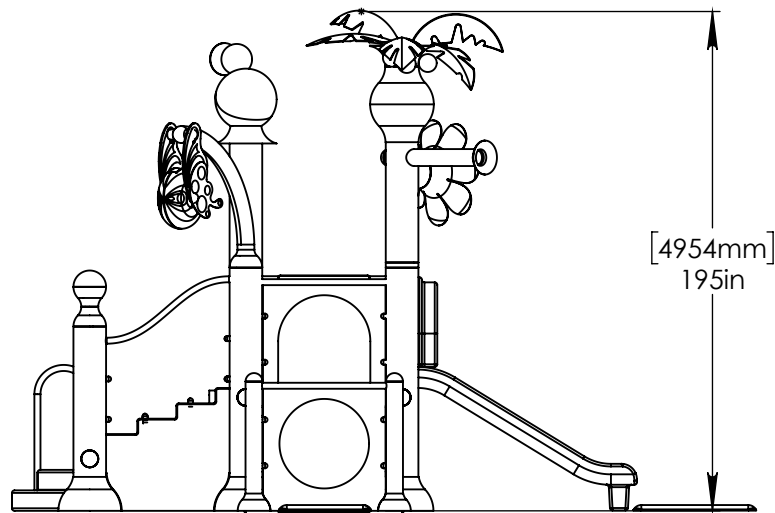
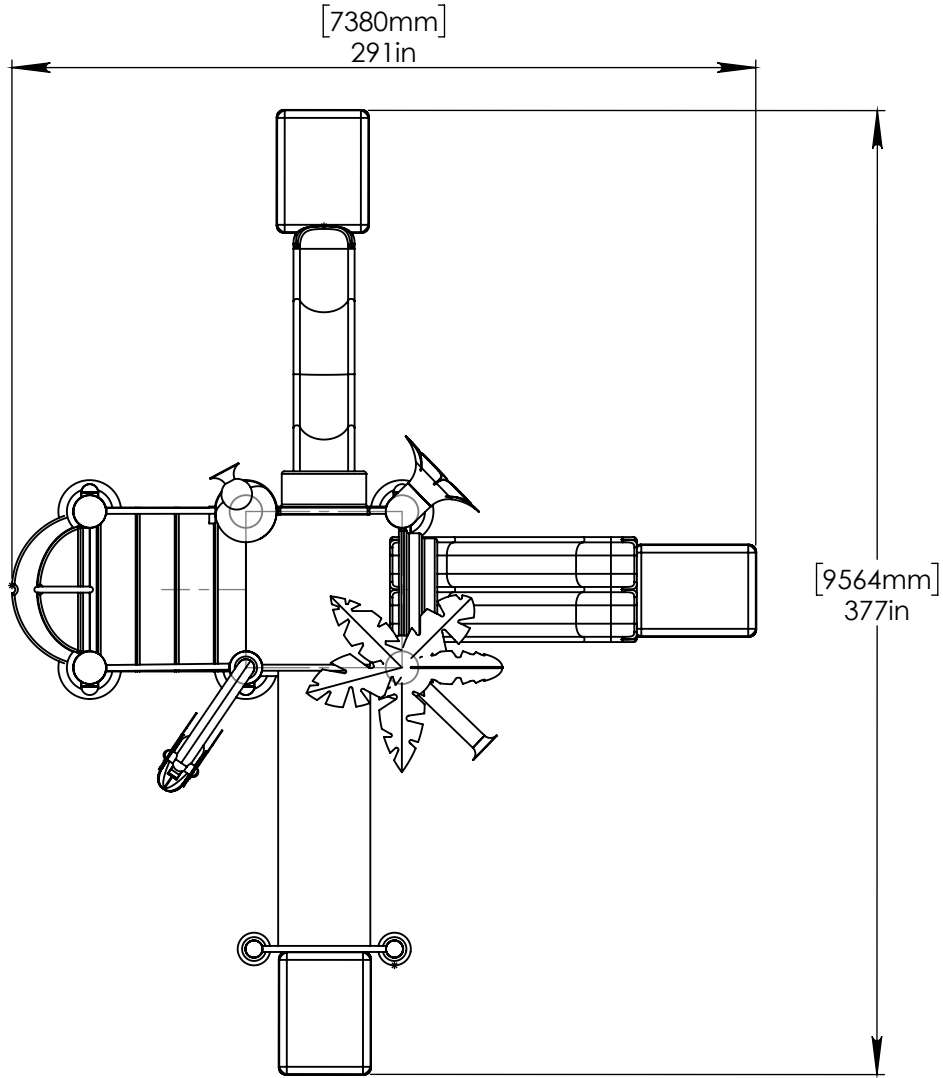

Notes: Overall dimensions of toys are approximate.

© EMPEX WATERTOYS

WATER SUPPLY
290 gpm @ 25 psi
18.3 L/S @17.5m

AQUADEK

T410-TR-3S

1/30/2017

SCALE:
1:75

Sheet
1 of 2

A

A

B

B

C

C

D

D

E

E

F

F

4"-6"
(100-150mm)
FLANGE NOT
PROVIDED BY
EMPEX

POOL SLAB

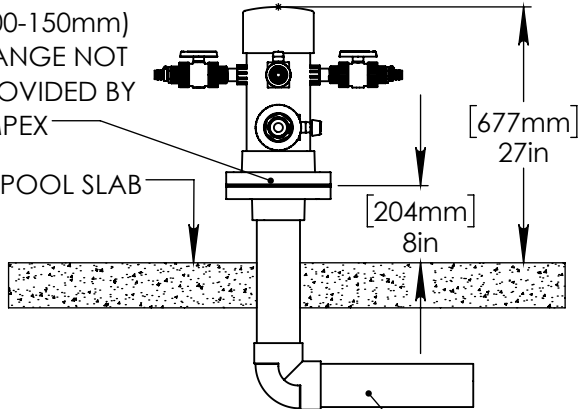

4" (150mm) PVC SCH 40
WATERFEED

(1) 2" (150mm) VALVE:
AQUAFALLS

(1) 1.5" (138mm) VALVE:
AQUATUBA FLOR

(3) 1" (100mm) VALVE:
(2) FINIAL
(1) AQUADUK

(1) 0.5" (50mm) VALVE:
(1) AQUADUNK

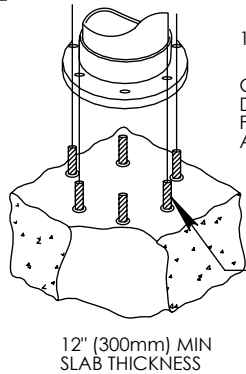
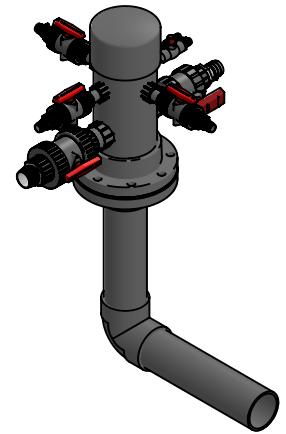

12" (300mm) COLUMN

CONCRETE TO BE
DRILLED ON SITE
FOR PLACEMENT OF
ANCHORS.

5/8 (16mm) CONCRETE
ANCHORS WITH NUT, LOCK WASHER
AND WASHER. MIN
6 ANCHORS.

12" (300mm) MIN
SLAB THICKNESS

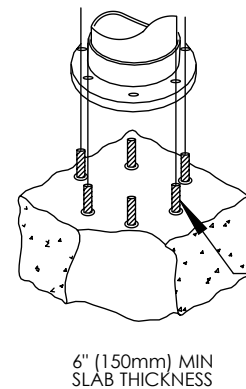

6" (150mm) COLUMN

CONCRETE TO BE
DRILLED ON SITE
FOR PLACEMENT OF
ANCHORS.

5/8 (16mm) CONCRETE
ANCHORS WITH NUT, LOCK WASHER
AND WASHER. MIN
4 ANCHORS.

6" (150mm) MIN
SLAB THICKNESS

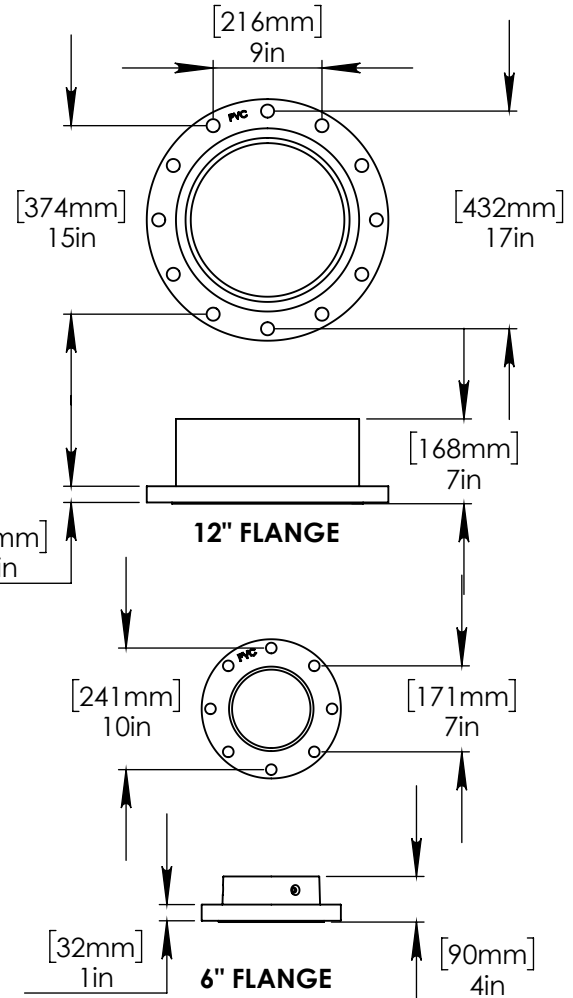

Notes: Overall dimensions of toys are approximate.

© EMPEX WATERTOYS

WATER SUPPLY
290 gpm @ 25 psi
18.3 L/S @ 17.5m

AQUADEK

T410-TR-3S

1/30/2017

SCALE:
1:10

Sheet
2 of 2