

NOTES:

- (1) PURGE ALL WATER SUPPLY LINES TO REMOVE SOLIDS PRIOR TO TOY INSTALLATION.
- (2) PROVIDE ELECTRICAL BOND WITH POOL REBAR.
- (3) INSTALL ALL WATER TOYS PLUMB AND LEVEL.
- (4) PROVIDE STRAINER UPSTREAM OF TOY WITH MAX 1#32" (0.8mm) PERFORATIONS.

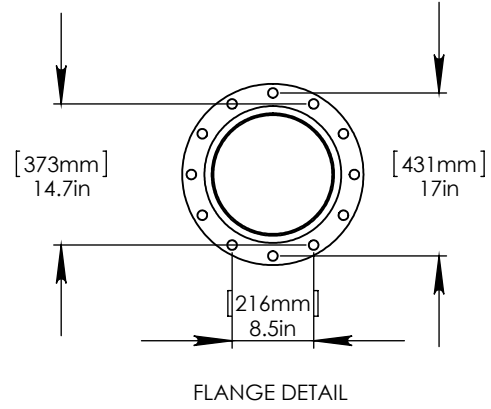

2" (50mm)-1" (25mm) FITTING TO BE PROVIDED BY CONTRACTOR.

STAINLESS STEEL (316) 5/8" (16mm) THREADED ROD, WASHER, LOCK WASHER, & NUT. THREADED ROD LENGTH 11" (280mm) WITH 6" (150mm) EMBEDMENT. USE MIN. 8 ANCHORS.

GRANULAR BASE

2" (50mm) PVC SCH 40 WATERFEED TO BE EXTENDED 8" (200mm) ABOVE SLAB.

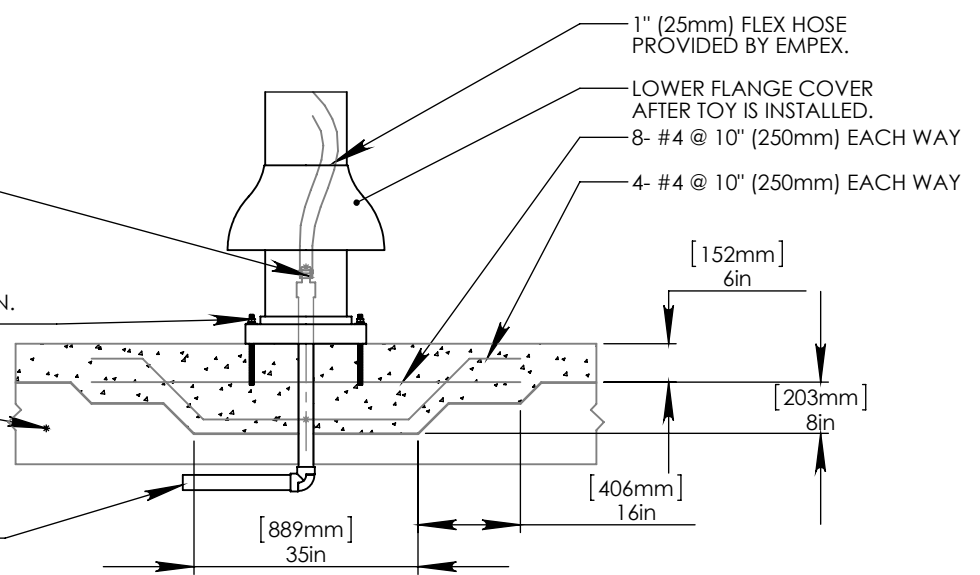

Notes: Overall dimensions of toys are approximate.

© EMPEX WATERTOYS



WATER SUPPLY
50 gpm @ 25 psi
3.15L/S @ 17.5m

FLYIN' FISH

T434

11/4/2014

SCALE:
1:60

Sheet
1 of 1