

ELEVATION VIEW

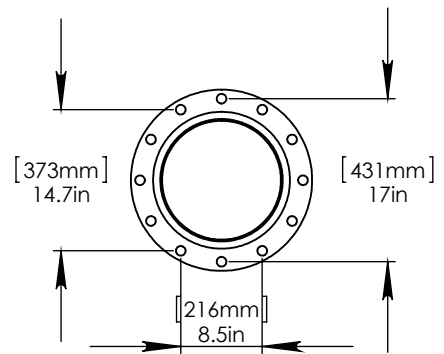

FLANGE DETAIL

NOTES:

(1) PURGE ALL WATER SUPPLY LINES TO REMOVE SOLIDS PRIOR TO TOY INSTALLATION.

(2) PROVIDE ELECTRICAL BOND WITH POOL REBAR.

(3) INSTALL ALL WATER TOYS PLUMB AND LEVEL.

(4) PROVIDE STRAINER UPSTREAM OF TOY WITH MAX #32" (0.8mm) PERFORATIONS.

2"(50mm)-1"(25mm) FITTING TO BE PROVIDED BY CONTRACTOR.

STAINLESS STEEL (316) 5/8" (16mm) THREADED ROD, WASHER, LOCK WASHER, & NUT. THREADED ROD LENGTH 11" (280mm) WITH 6" (150mm) EMBEDMENT. USE MIN. 8 ANCHORS.

GRANULAR BASE

2"(50mm) PVC SCH 40 WATERFEED TO BE EXTENDED 8"(200mm) ABOVE SLAB.

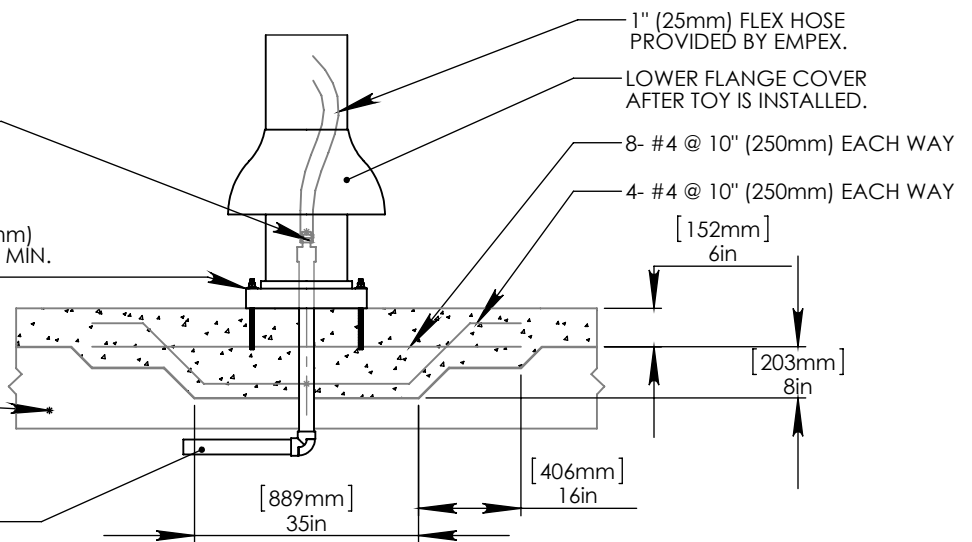

1" (25mm) FLEX HOSE PROVIDED BY EMPEX.

LOWER FLANGE COVER AFTER TOY IS INSTALLED.

8- #4 @ 10" (250mm) EACH WAY

4- #4 @ 10" (250mm) EACH WAY

Notes: Overall dimensions of toys are approximate.

© EMPEX WATERTOYS



WATER SUPPLY

50 gpm @ 25 psi
3.15L/S @ 17.5m

TIPPIN' LOLLIES

T435

11/4/2014

SCALE:
1:60

Sheet
1 of 1