

NOTES:

(1) PURGE ALL WATER SUPPLY LINES TO REMOVE SOLIDS PRIOR TO TOY INSTALLATION.

(2) PROVIDE ELECTRICAL BOND WITH POOL REBAR.

(3) INSTALL ALL WATER TOYS PLUMB AND LEVEL.

(4) PROVIDE STRAINER UPSTREAM OF TOY WITH MAX 1/32" (0.8mm) PERFORATIONS.

(5) TOY MUST BE INSTALLED ON FLAT SURFACE.

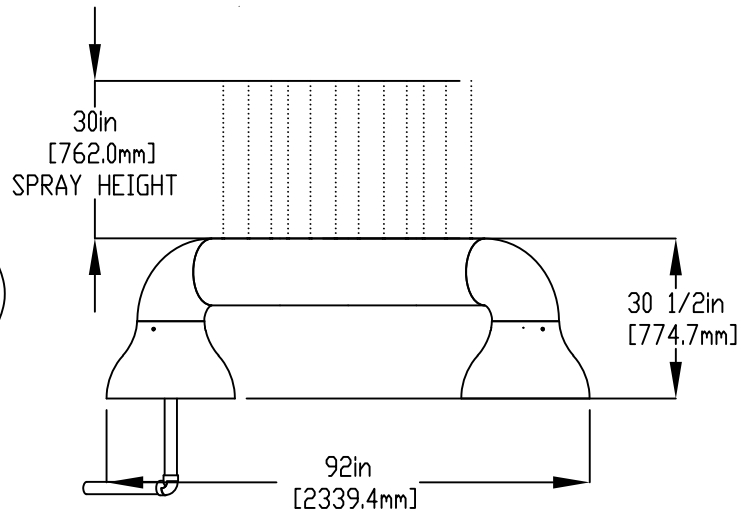
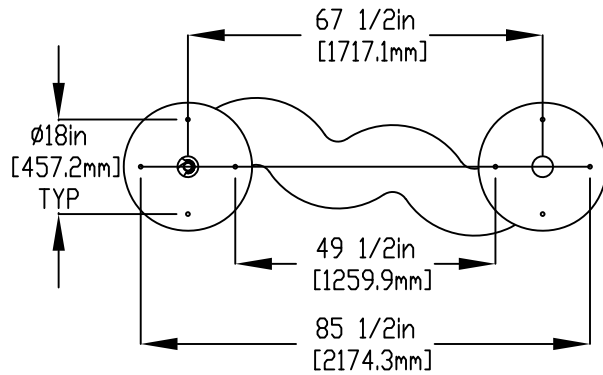
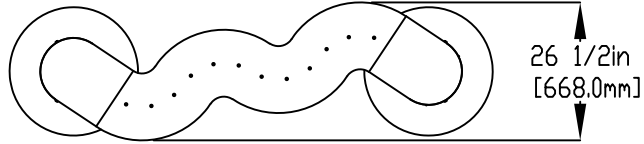

2" (50mm) COUPLING  
 2" (50mm) TO 1-1/2" (38mm REDUCER)  
 1-1/2" (38mm) HOSEBARB W/SS CLAMP  
 TO BE PROVIDED BY CONTRACTOR

1-1/2" (38mm) FLEX HOSE  
 PROVIDED BY EMPEX

1/2" (13mm) X 8" (203mm) 316SS  
 THREADED ROD, C/W FENDER WASHER,  
 LOCK WASHER & UT (X4) MINIMUM  
 6" (152mm) EMBEDMENT, EPOXY SET  
 ANCHOR ADHESIVE  
 TO BE PROVIDED BY CONTRACTOR

1. Bolt insert sleeve
2. Make Plumbing connection
3. Lower Toy & Bolt to Insert

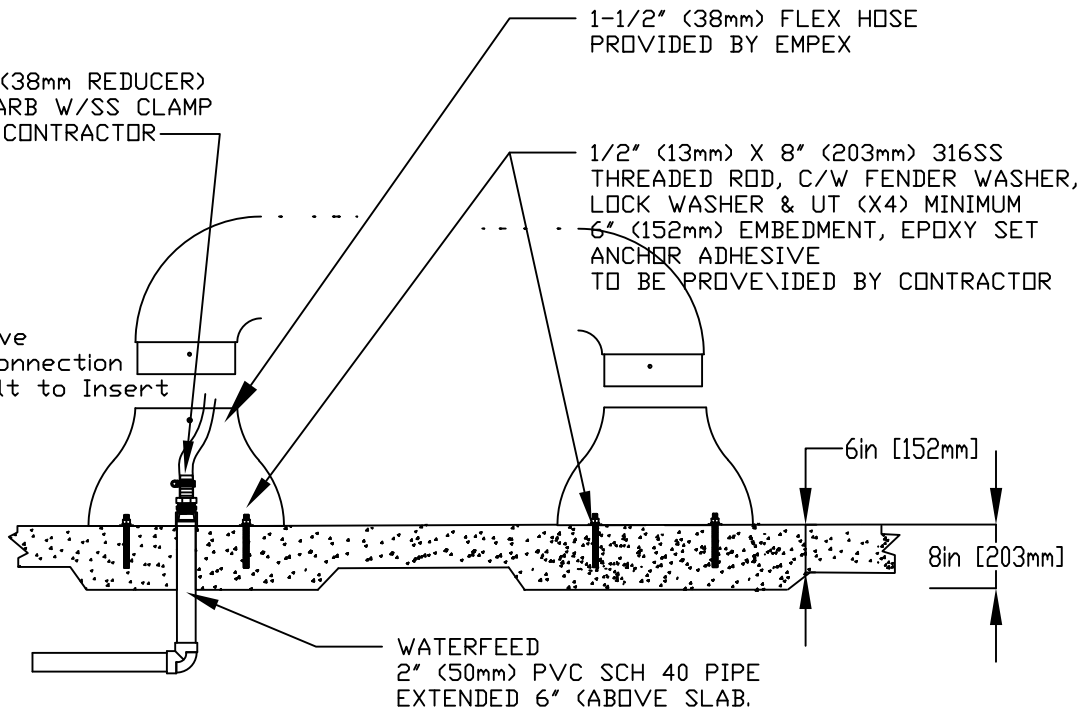

Notes: Overall dimensions of toys are approximate.  
 Approximate Weight: 42lbs / 19.1kgs

© EMPEX WATERTOYS



WATER SUPPLY

60 gpm @ 25 psi  
 3.8L/S @17.5m

AQUAFLO

T602

24/04/2023

SCALE:

Sheet  
 1 of 1