

NOTES:

(1) PURGE ALL WATER SUPPLY LINES TO REMOVE SOLIDS PRIOR TO TOY INSTALLATION.

(2) PROVIDE ELECTRICAL BOND WITH POOL REBAR.

(3) INSTALL ALL WATER TOYS PLUMB AND LEVEL.

(4) PROVIDE STRAINER UPSTREAM OF TOY WITH MAX 1/32" (0.8mm) PERFORATIONS.

A

A

B

B

C

C

D

D

E

E

F

F

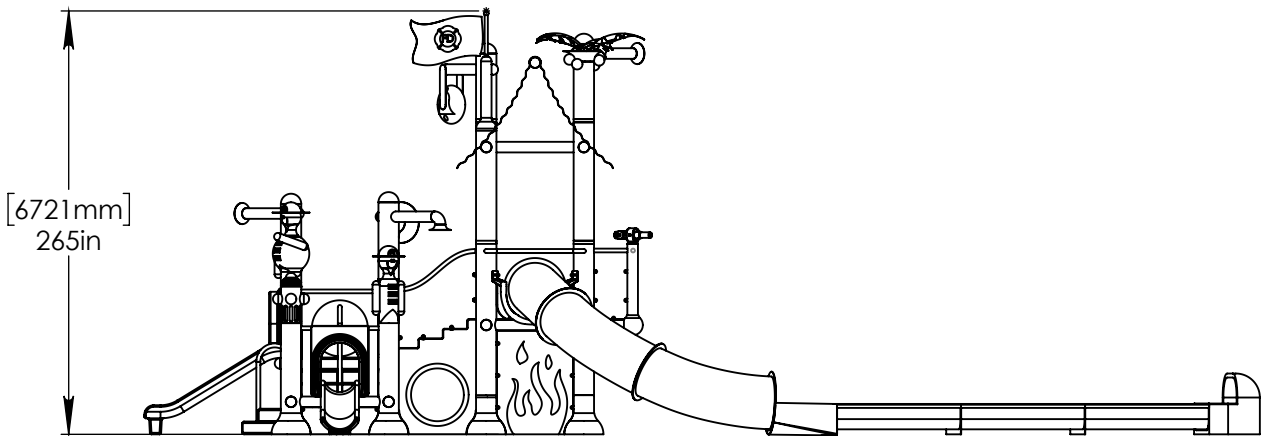
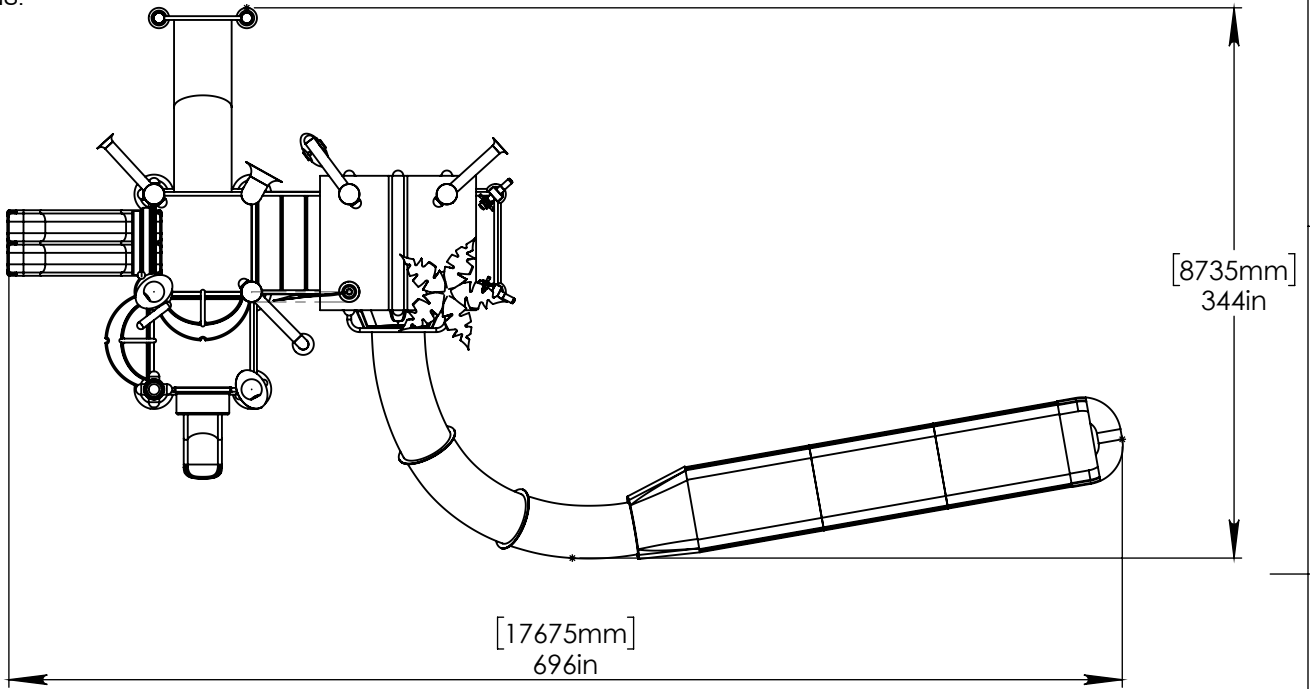

Notes: Overall dimensions of toys are approximate.

© EMPEX WATERTOYS

WATER SUPPLY

590 gpm @ 25 psi
40L/S @17.5m

AQUADEK

T610-F-246R

7/22/2016

SCALE:
1:120

Sheet
1 of 3

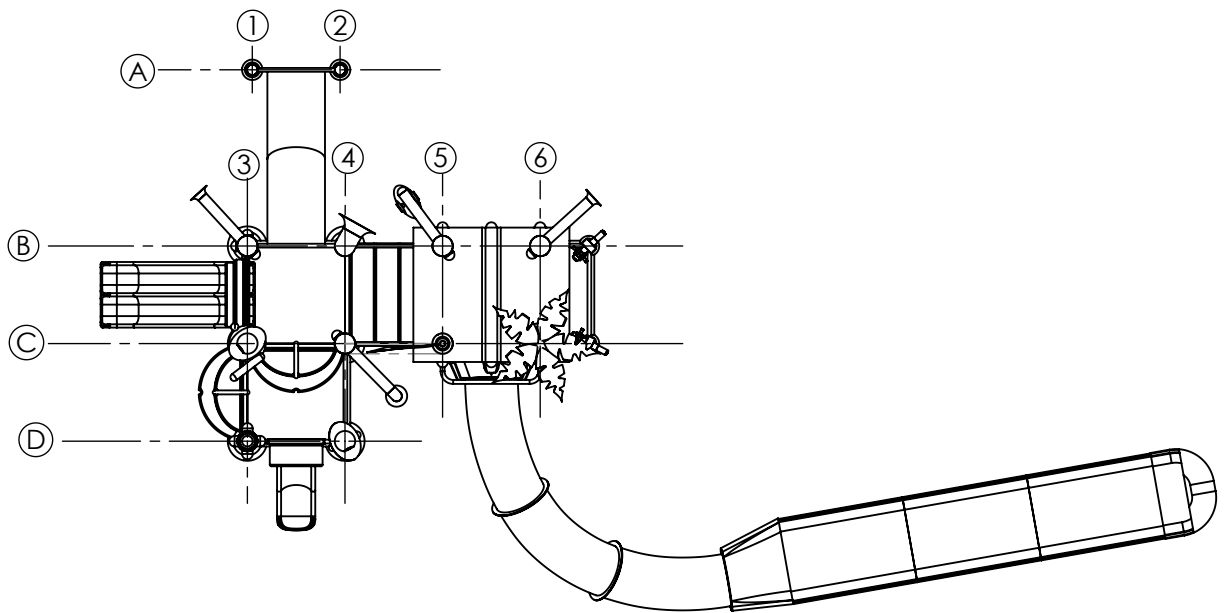

12" AQUADEK COLUMN MOUNTING FLANGE DETAIL.

COLUMNS 3B,3C,3D,4B,4C,44D,5B,5C,6B,6C.

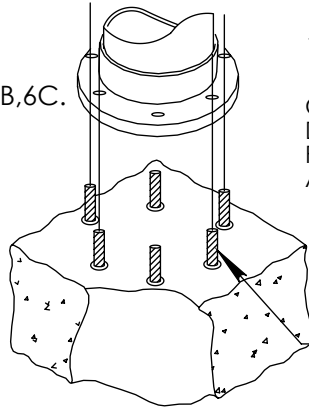

12" (300mm) COLUMN

CONCRETE TO BE DRILLED ON SITE FOR PLACEMENT OF ANCHORS.

5/8 (16mm) CONCRETE ANCHORS WITH NUT, LOCK WASHER AND WASHER. MIN 6 ANCHORS.

12" (300mm) MIN SLAB THICKNESS

6" AQUADEK COLUMN MOUNTING FLANGE DETAIL.

COLUMNS 1A,2A.

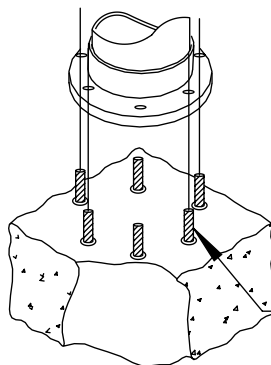

6" (150mm) COLUMN

CONCRETE TO BE DRILLED ON SITE FOR PLACEMENT OF ANCHORS.

5/8 (16mm) CONCRETE ANCHORS WITH NUT, LOCK WASHER AND WASHER. MIN 4 ANCHORS.

6" (150mm) MIN SLAB THICKNESS

Notes: Overall dimensions of toys are approximate.

© EMPEX WATERTOYS



WATER SUPPLY
590 gpm @ 25 psi
40L/S @17.5m

AQUADEK

T610-F-246R

7/22/2016

SCALE:
1:120

Sheet
2 of 3

A

A

B

B

C

C

D

D

E

E

F

F

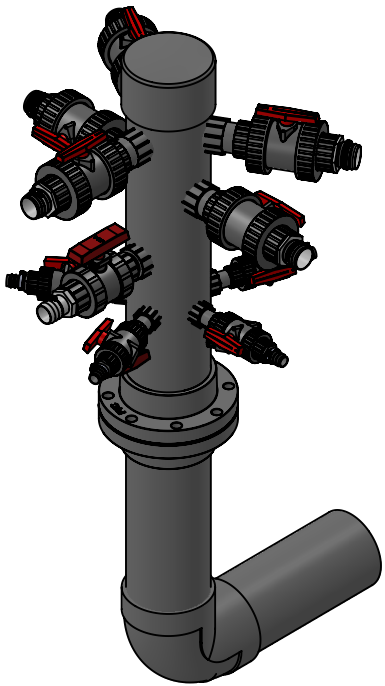

TOTAL 14 MANIFOLD VALVES:
 (5) 2" VALVES FOR (2) FALLS AND (3) FG SLIDE
 (1) 1 1/2" VALVE FOR TUBA
 (5) 1" VALVE FOR CURTAIN, SHOWER, FIREMAN 1, FIREMAN 2, HYDRANT.
 (3) 1/2" VALVES FOR SHOOTER 1, SHOOTER 2, TIPPER.

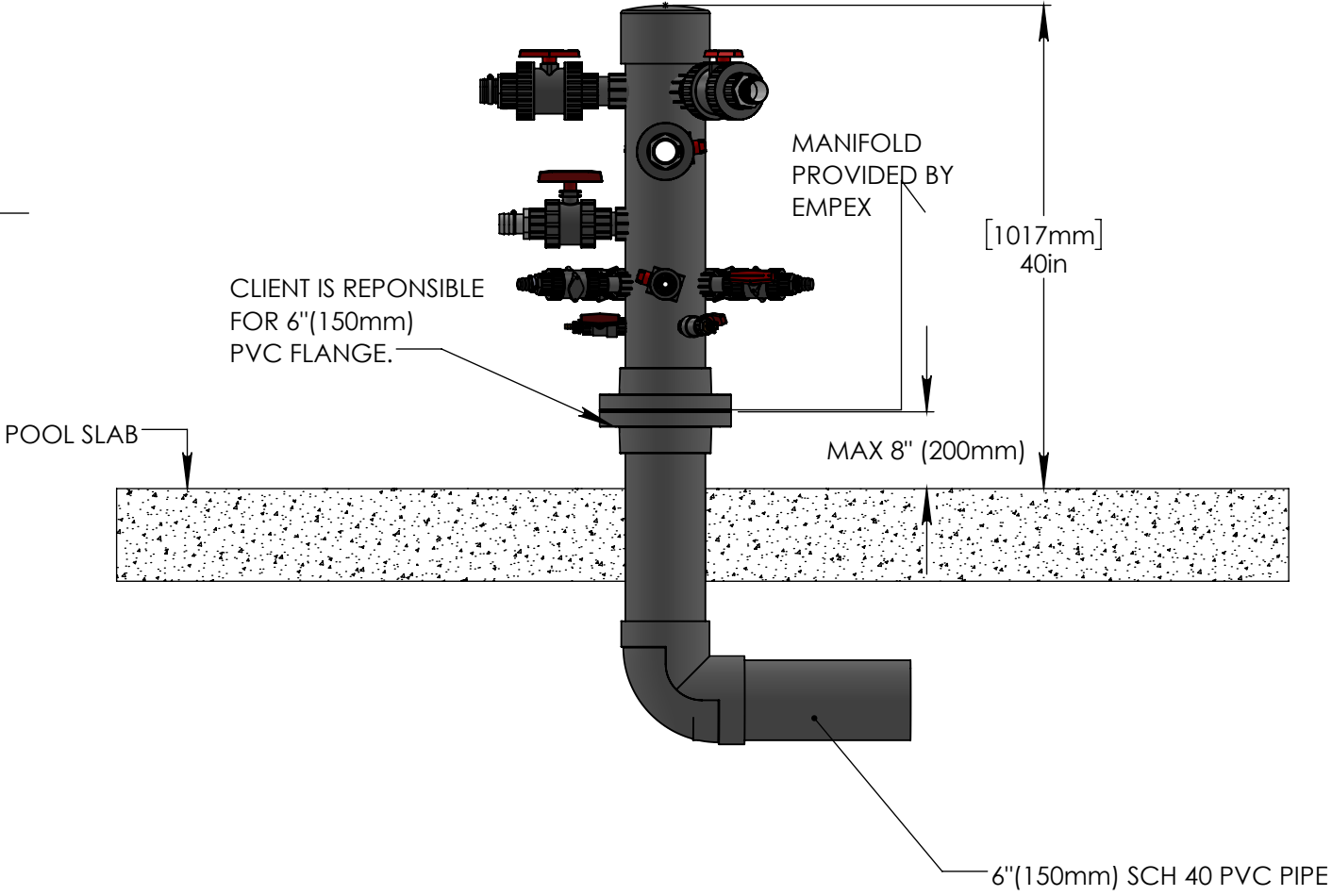

Notes: Overall dimensions of toys are approximate.

© EMPEX WATERTOYS

WATER SUPPLY
 590 gpm @ 25 psi
 40L/S @17.5m

AQUADEK

T610-F-246R

7/22/2016

SCALE:
1:15

Sheet
3 of 3