

NOTES:

(1) PURGE ALL WATER SUPPLY LINES TO REMOVE SOLIDS PRIOR TO TOY INSTALLATION.

(2) PROVIDE ELECTRICAL BOND WITH POOL REBAR.

(3) INSTALL ALL WATER TOYS PLUMB AND LEVEL.

(4) PROVIDE STRAINER UPSTREAM OF TOY WITH MAX 1#32" (0.8mm) PERFORATIONS.

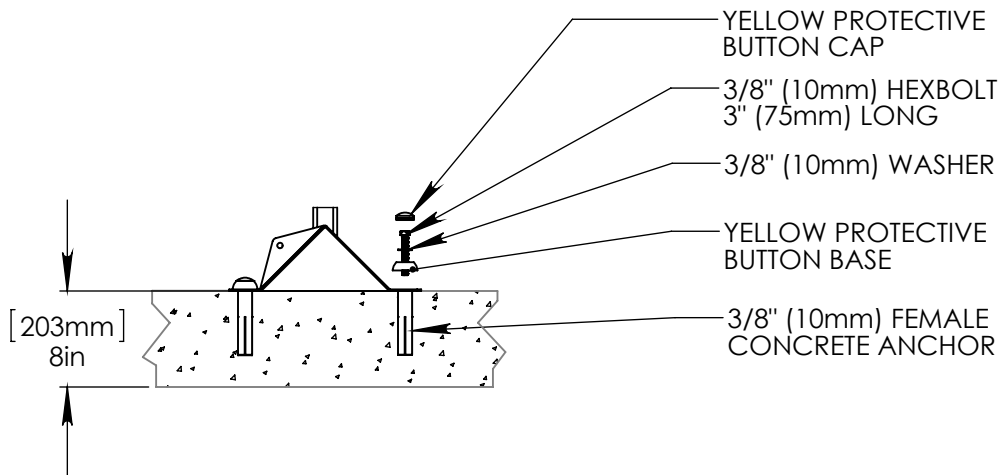
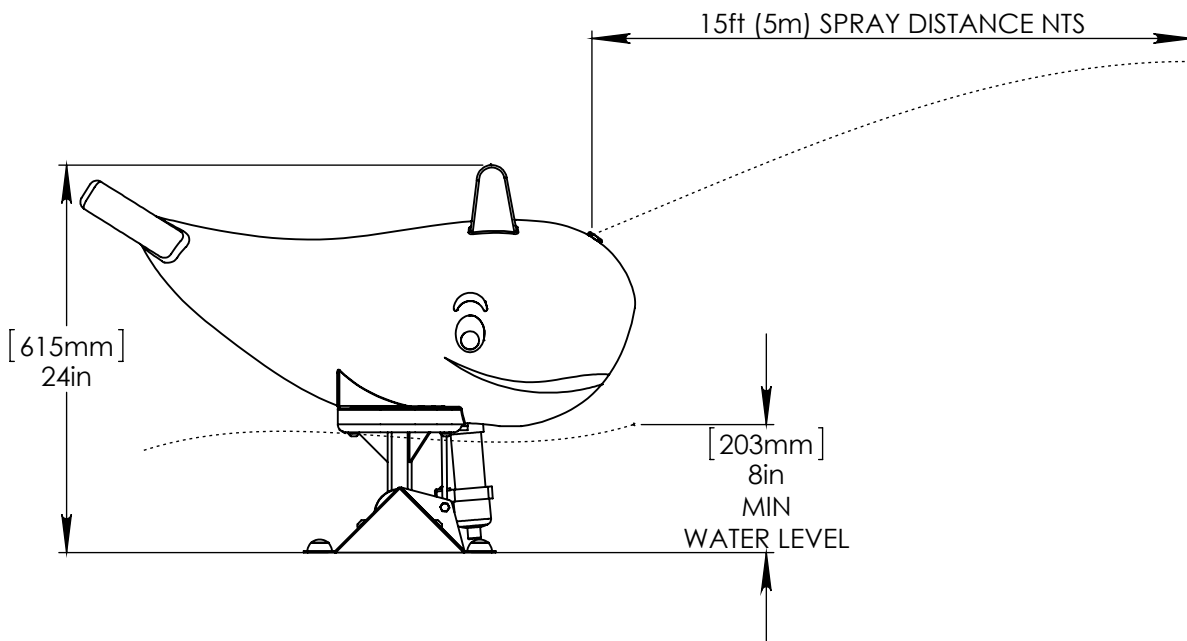
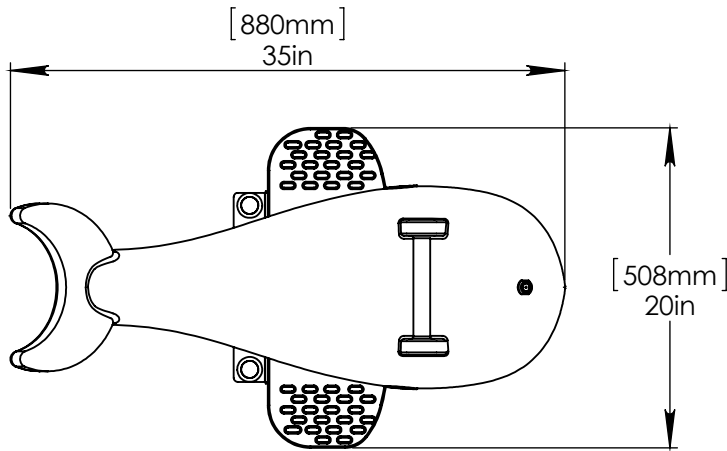

Notes: Overall dimensions of toys are approximate.

© EMPEX WATERTOYS



WATER SUPPLY
NO EXTERNAL SUPPLY
NEEDED.

SQUIRTIN WHALE

T613

11/5/2014

SCALE:
1:12

Sheet
1 of 1