

NOTES:

- (1) PURGE ALL WATER SUPPLY LINES TO REMOVE SOLIDS PRIOR TO TOY INSTALLATION.
- (2) PROVIDE ELECTRICAL BOND WITH POOL REBAR.
- (3) INSTALL ALL WATER TOYS PLUMB AND LEVEL.
- (4) PROVIDE STRAINER UPSTREAM OF TOY WITH MAX 1#32" (0.8mm) PERFORATIONS.

- 2"(50mm)-1"(25mm) FITTING TO BE PROVIDED BY CONTRACTOR.
- STAINLESS STEEL (316) 5/8" (16mm) THREADED ROD, WASHER, LOCK WASHER, & NUT. THREADED ROD LENGTH 11" (280mm) WITH 6" (150mm) EMBEDMENT. USE MIN. 8 ANCHORS.
- GRANULAR BASE
- 2"(50mm) PVC SCH 40 WATERFEED TO BE EXTENDED 8"(200mm) ABOVE SLAB.

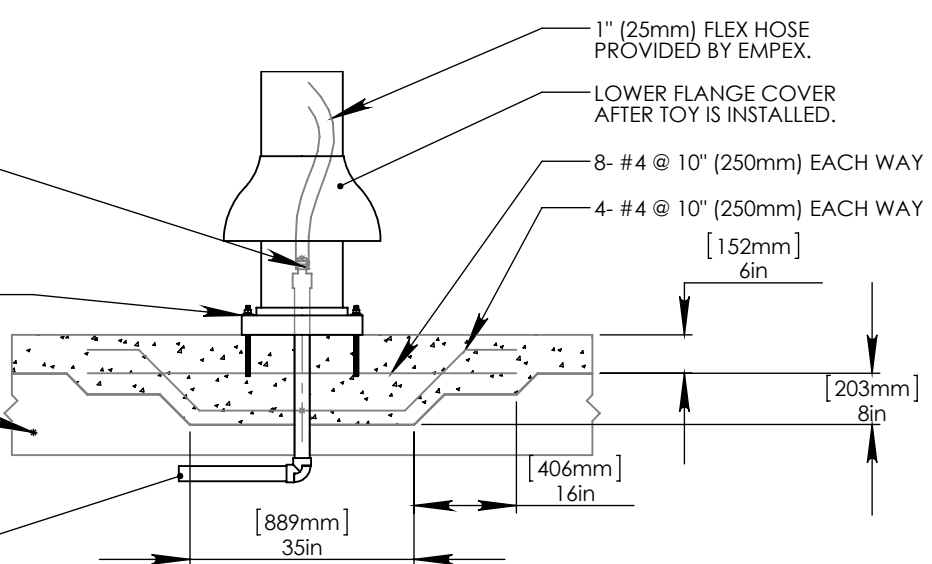

Notes: Overall dimensions of toys are approximate.

© EMPEX WATERTOYS



WATER SUPPLY
 50 gpm @ 25 psi
 3.15L/S @ 17.5m

SPLASHIN' PIRATES

T724	3/30/2015	SCALE: 1:60	Sheet 1 of 1
------	-----------	----------------	-----------------