

**NOTES:**

(1) PURGE ALL WATER SUPPLY LINES TO REMOVE SOLIDS PRIOR TO TOY INSTALLATION.

(2) PROVIDE ELECTRICAL BOND WITH POOL REBAR.

(3) INSTALL ALL WATER TOYS PLUMB AND LEVEL.

(4) PROVIDE STRAINER UPSTREAM OF TOY WITH MAX 1/32" (0.8mm) PERFORATIONS.

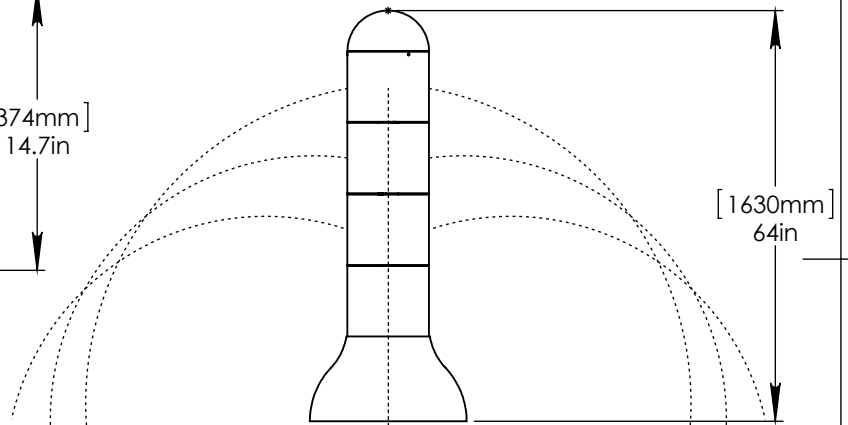
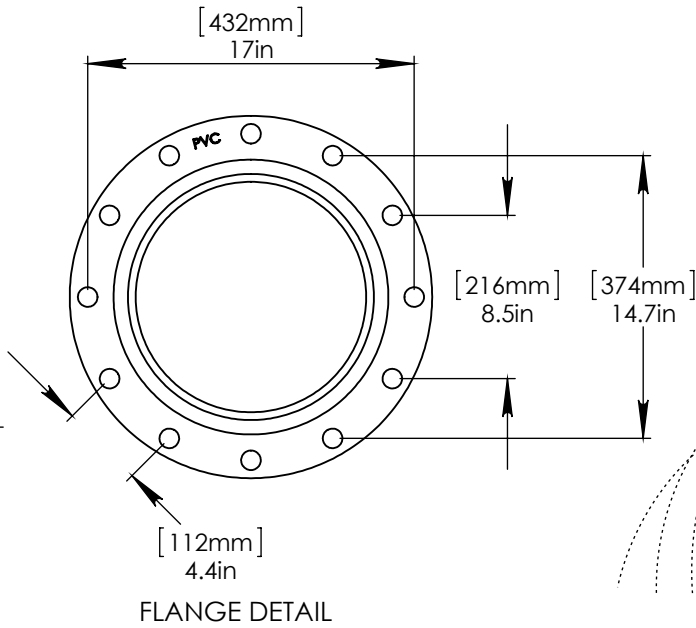
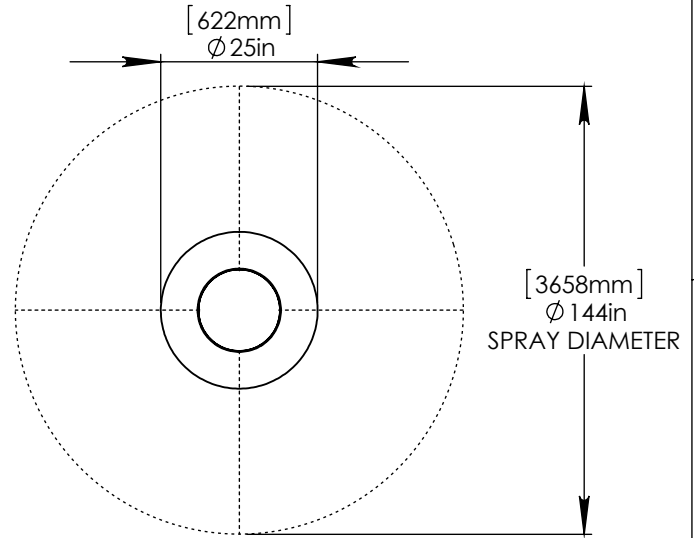

LOWER FLANGE COVER AFTER TOY IS INSTALLED.

STAINLESS STEEL (316) 5/8" (16mm) THREADED ROD, WASHER, LOCK WASHER, & NUT. THREADED ROD LENGTH 7" (180mm) WITH 4" (100mm) EMBEDMENT.

2" (50mm) SCH 40 PVC WATERFEED TO BE EXTENDED 8" (200mm) ABOVE SLAB.

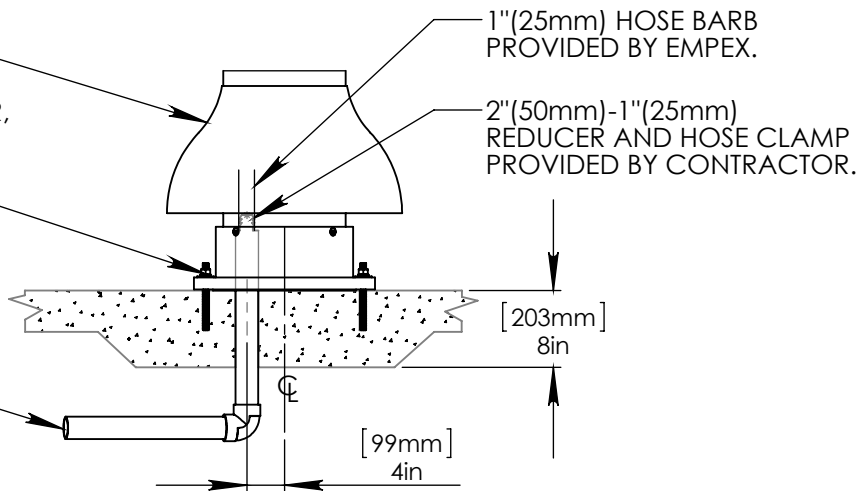

Notes: Overall dimensions of toys are approximate.

© EMPEX WATERTOYS

**WATER SUPPLY**  
30 gpm @ 25 psi  
1.89L/S @ 17.5m

# AQUATWISTER

**T823**

5/14/2015

SCALE:  
1:30

Sheet  
1 of 1