

NOTES:

(1) PURGE ALL WATER SUPPLY LINES TO REMOVE SOLIDS PRIOR TO TOY INSTALLATION.

(2) PROVIDE ELECTRICAL BOND WITH POOL REBAR.

(3) INSTALL ALL WATER TOYS PLUMB AND LEVEL.

(4) PROVIDE STRAINER UPSTREAM OF TOY WITH MAX 1#32" (0.8mm) PERFORATIONS.

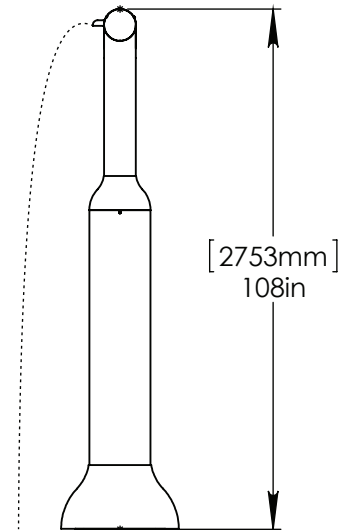
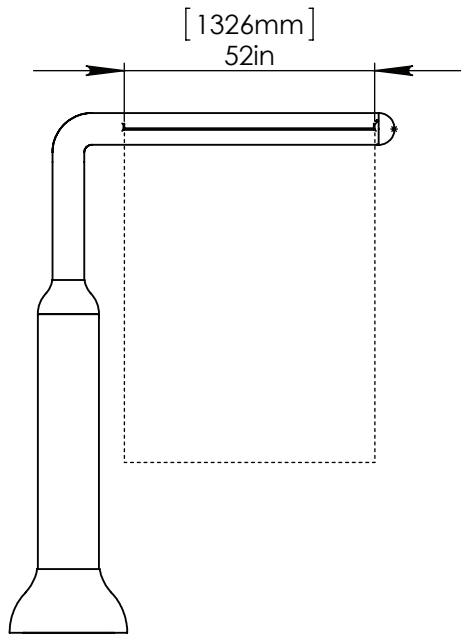
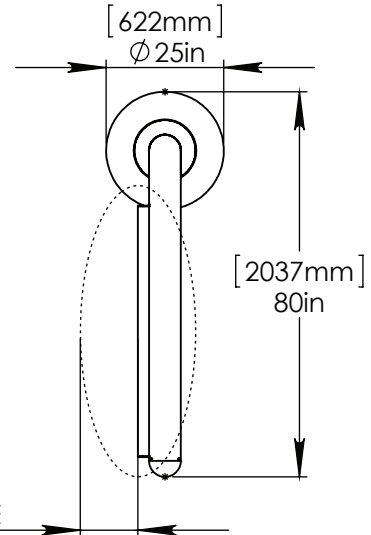
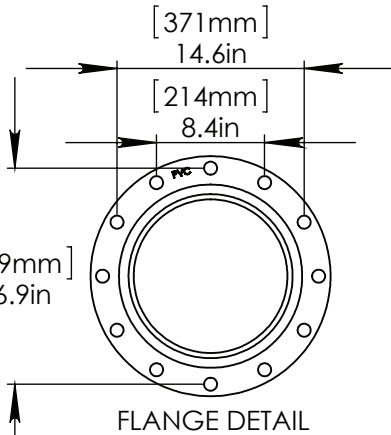

STAINLESS STEEL (316)  
 5/8" (16mm) THREADED ROD, WASHER,  
 LOCK WASHER, & NUT.  
 THREADED ROD LENGTH 9" (230mm)  
 WITH 6" (150mm) EMBEDMENT. USE  
 MINIMUM 6 ANCHORS.

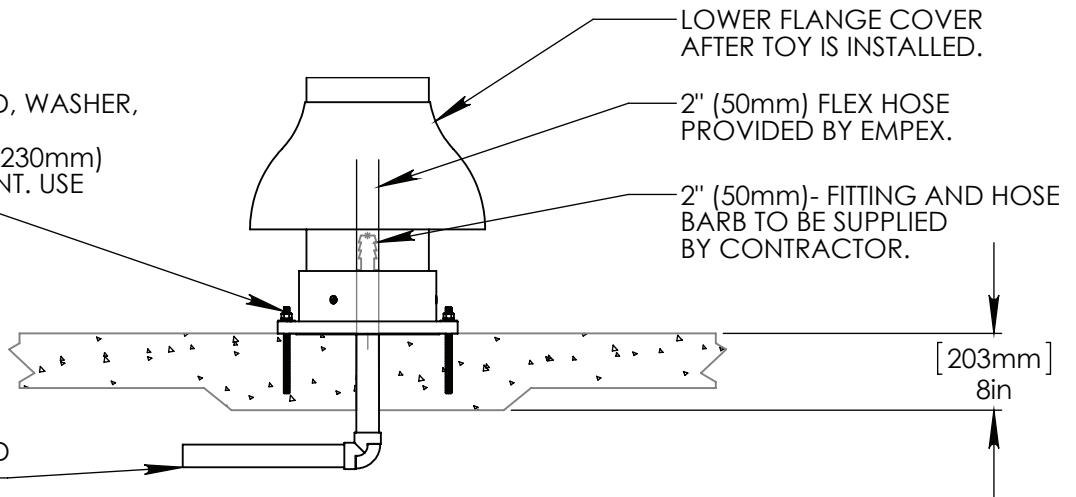

Notes: Overall dimensions of toys are approximate.

© EMPEX WATERTOYS

WATER SUPPLY

60 gpm @ 20 psi  
3.8 L/S @ 14m

AQUASHEET

T861

9/17/2014

SCALE:  
1:40

Sheet  
1 of 1