

**NOTES:**

- (1) PURGE ALL WATER SUPPLY LINES TO REMOVE SOLIDS PRIOR TO TOY INSTALLATION.
- (2) PROVIDE ELECTRICAL BOND WITH POOL REBAR.
- (3) INSTALL ALL WATER TOYS PLUMB AND LEVEL.
- (4) PROVIDE STRAINER UPSTREAM OF TOY WITH MAX 1#32" (0.8mm) PERFORATIONS.

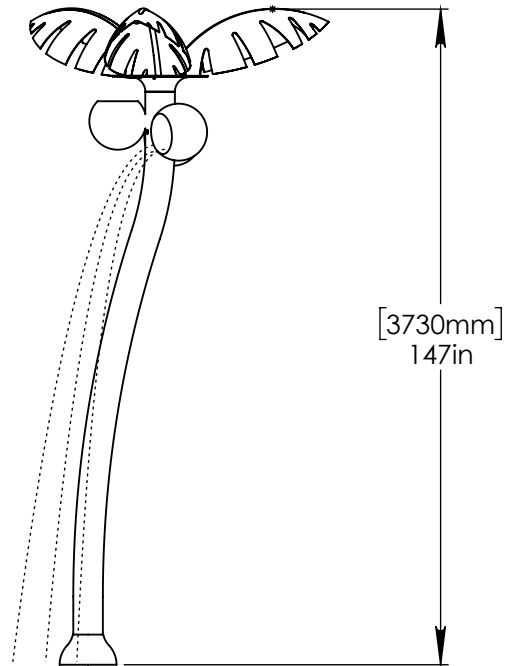
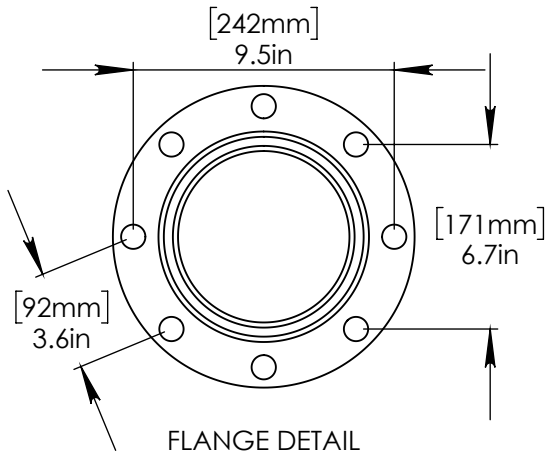
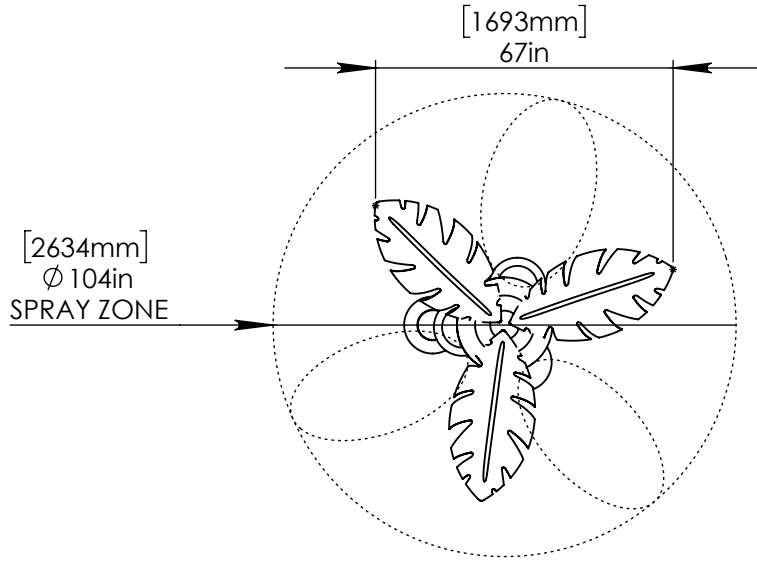

LOWER FLANGE COVER AFTER TOY IS INSTALLED.

STAINLESS STEEL (316) 5/8" (16mm) THREADED ROD, WASHER, LOCK WASHER, & NUT. THREADED ROD LENGTH 9" (230mm) WITH 6" (150mm) EMBEDMENT. USE MINIMUM 6 ANCHORS.

2" (50mm) SCH 40 PVC WATER FEED TO BE EXTENDED 8" (200mm) ABOVE POOL SLAB.

1" (25mm) FLEX HOSE PROVIDED BY EMPEX.

2" (50mm)-1" (25mm) FITTING AND HOSE CLAMP TO BE PROVIDED BY CONTRACTOR.

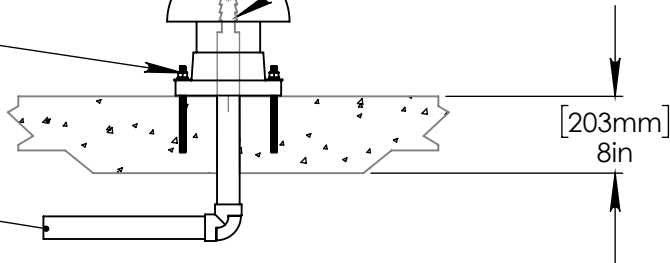

Notes: Overall dimensions of toys are approximate.

© EMPEX WATERTOYS

# COCONUT SPLASH

**WATER SUPPLY**  
30 gpm @ 25 psi  
1.89L/S @ 17.5m

**TR328**

7/20/2016

SCALE:  
1:43

Sheet  
1 of 1