

NOTES:

(1) PURGE ALL WATER SUPPLY LINES TO REMOVE SOLIDS PRIOR TO TOY INSTALLATION.

(2) PROVIDE ELECTRICAL BOND WITH POOL REBAR.

(3) INSTALL ALL WATER TOYS PLUMB AND LEVEL.

(4) PROVIDE STRAINER UPSTREAM OF TOY WITH MAX 1/32" (0.8mm) PERFORATIONS.

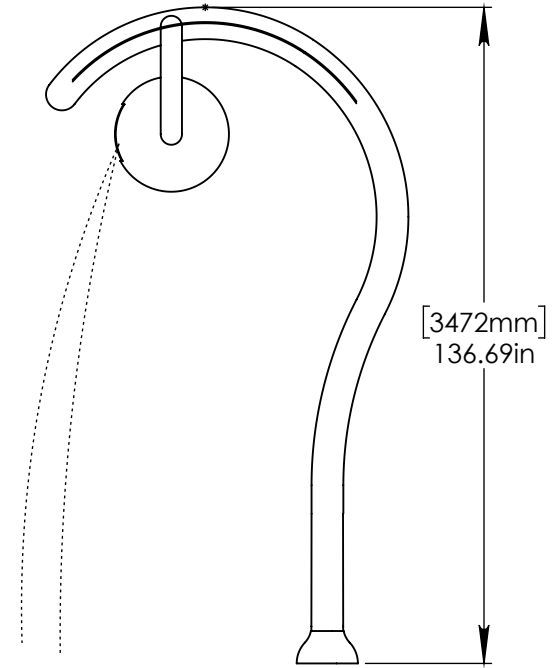
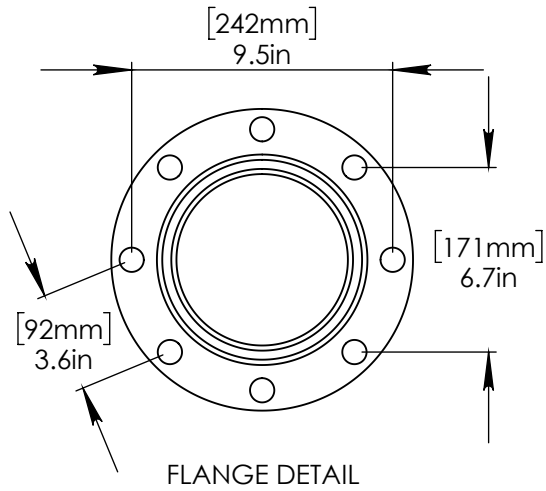
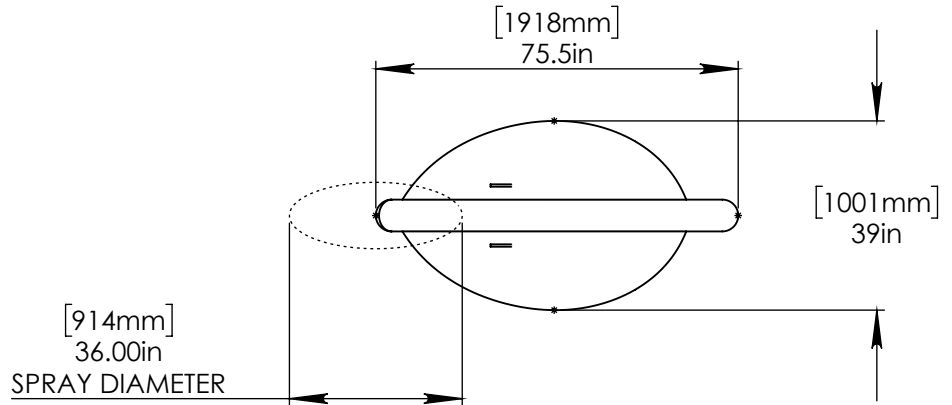

2" (50mm)-3/4" (19mm) FITTING AND HOSE CLAMP TO BE PROVIDED BY CONTRACTOR.

STAINLESS STEEL (316)
5/8" (16mm) THREADED ROD, WASHER, LOCK WASHER, & NUT.
THREADED ROD LENGTH 9" (230mm) WITH 6" (150mm) EMBEDMENT. USE MINIMUM 6 ANCHORS. (ANCHORS NOT SUPPLIED BY EMPEX)

LOWER FLANGE COVER AFTER TOY IS INSTALLED.

2" (50mm) SCH 40 PVC WATER FEED TO BE EXTENDED 8" (200mm) ABOVE SLAB.

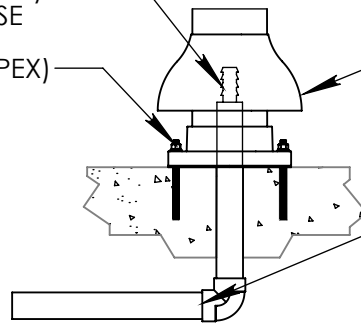

Notes: Overall dimensions of toys are approximate.

© EMPEX WATERTOYS

WATER SUPPLY
30 gpm @ 25 psi
1.89 L/S @ 17.5m

AQUALEAF

TR346

1/23/2019

SCALE:
1:40

Sheet
1 of 1