

NOTES:

(1) PURGE ALL WATER SUPPLY LINES TO REMOVE SOLIDS PRIOR TO TOY INSTALLATION.

(2) PROVIDE ELECTRICAL BOND WITH POOL REBAR.

(3) INSTALL ALL WATER TOYS PLUMB AND LEVEL.

(4) PROVIDE STRAINER UPSTREAM OF TOY WITH MAX 1/32" (0.8mm) PERFORATIONS.

A

A

B

B

C

C

D

D

E

E

F

F

[3048mm]
Ø 120in
SPRAY DIAMETER

[2428mm]
96in

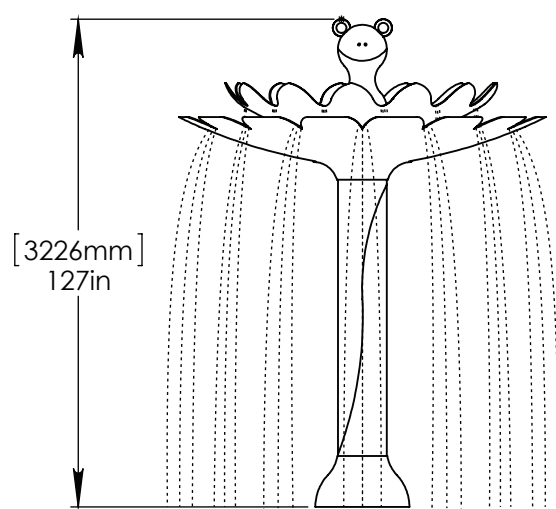
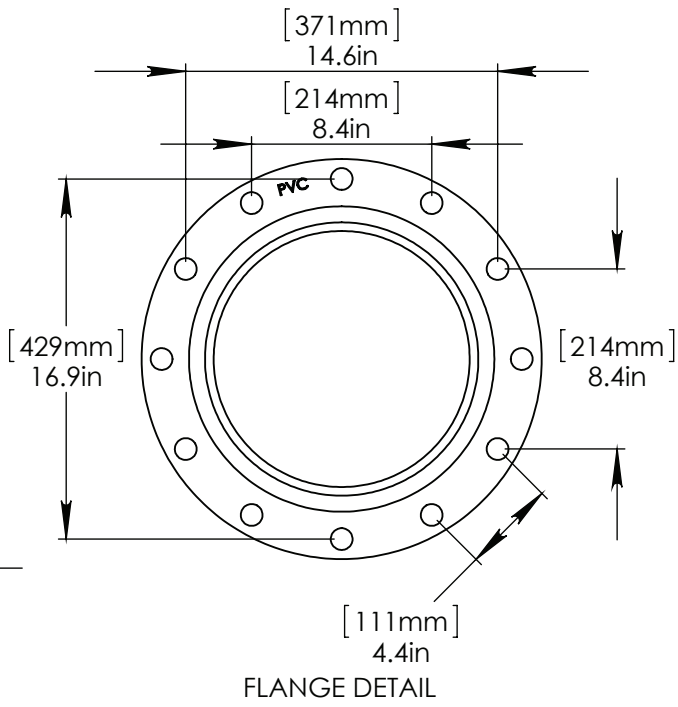

LOWER FLANGE COVER AFTER TOY IS INSTALLED.

STAINLESS STEEL (316) 5/8" (16mm) THREADED ROD, WASHER, LOCK WASHER, & NUT. THREADED ROD LENGTH 9" (230mm) WITH 6" (150mm) EMBEDMENT. USE MIN. 8 ANCHORS.

GRANULAR BASE

4" (100mm) PVC SCH 40 WATERFEED TO BE EXTENDED 8" (200mm) ABOVE SLAB.

ENSURE LEVEL SURFACE. INSTALL Ø 12" X 1/8" GASKET UNDER COLUMN PIPE FLANGE.

8- #4 @ 10" (250mm) EACH WAY

4- #4 @ 10" (250mm) EACH WAY

[152mm]
6in

[203mm]
8in

[406mm]
16in

[889mm]
35in

Notes: Overall dimensions of toys are approximate.

© EMPEX WATERTOYS



WATER SUPPLY
400 gpm @ 10 psi
25.3 L/S @ 7 m

AQUALILLY

TR890

9/17/2014

SCALE:
1:50

Sheet
1 of 1