

1

2

3

4

NOTES:

(1) PURGE ALL WATER SUPPLY LINES TO REMOVE SOLIDS PRIOR TO TOY INSTALLATION.

(2) PROVIDE ELECTRICAL BOND WITH POOL REBAR.

(3) INSTALL ALL WATER TOYS PLUMB AND LEVEL.

(4) PROVIDE STRAINER UPSTREAM OF TOY WITH MAX 1/32" (0.8mm) PERFORATIONS.

A

A

B

B

C

C

D

D

E

E

F

F

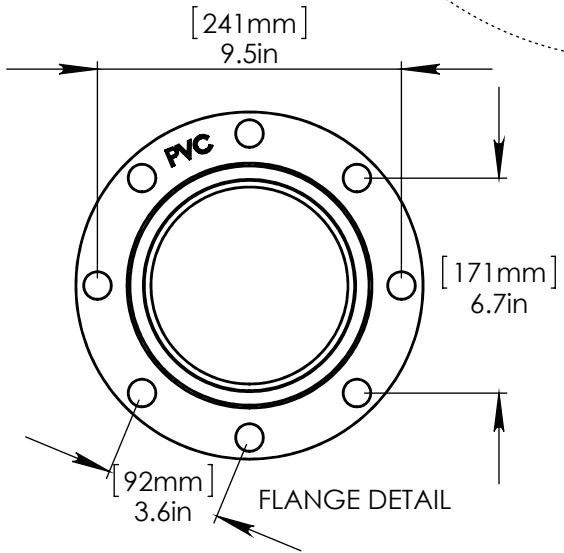
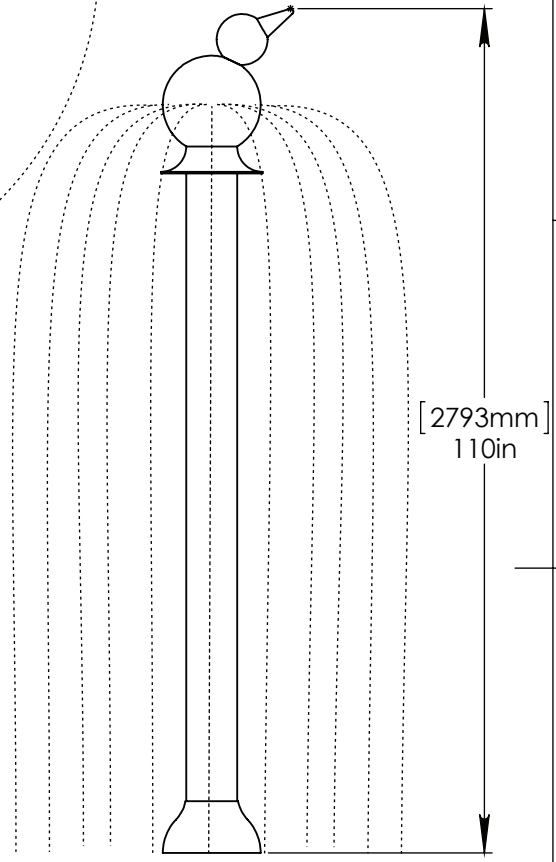
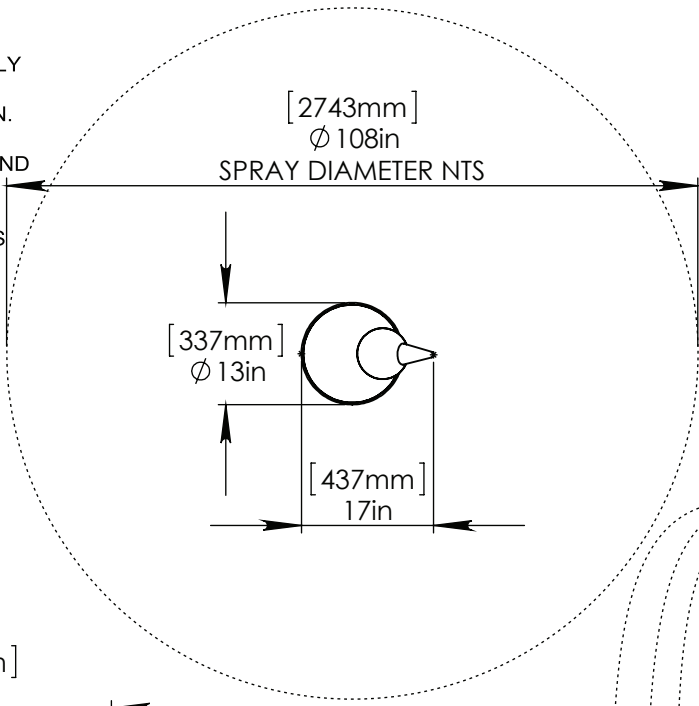

LOWER FLANGE COVER AFTER TOY IS INSTALLED.

STAINLESS STEEL (316) 5/8" (16mm) THREADED ROD, WASHER, LOCK WASHER, & NUT. THREADED ROD LENGTH 9" (230mm) WITH 6" (150mm) EMBEDMENT. USE MINIMUM 6 ANCHORS.

1" (25mm) FLEX HOSE PROVIDED BY EMPEX.

2" (50mm)-1" (25mm) FITTING AND HOSE BARB TO BE SUPPLIED BY CONTRACTOR.

2" (50mm) SCH 40 PVC WATERFEED TO BE EXTENDED 8" (200mm) ABOVE SLAB.

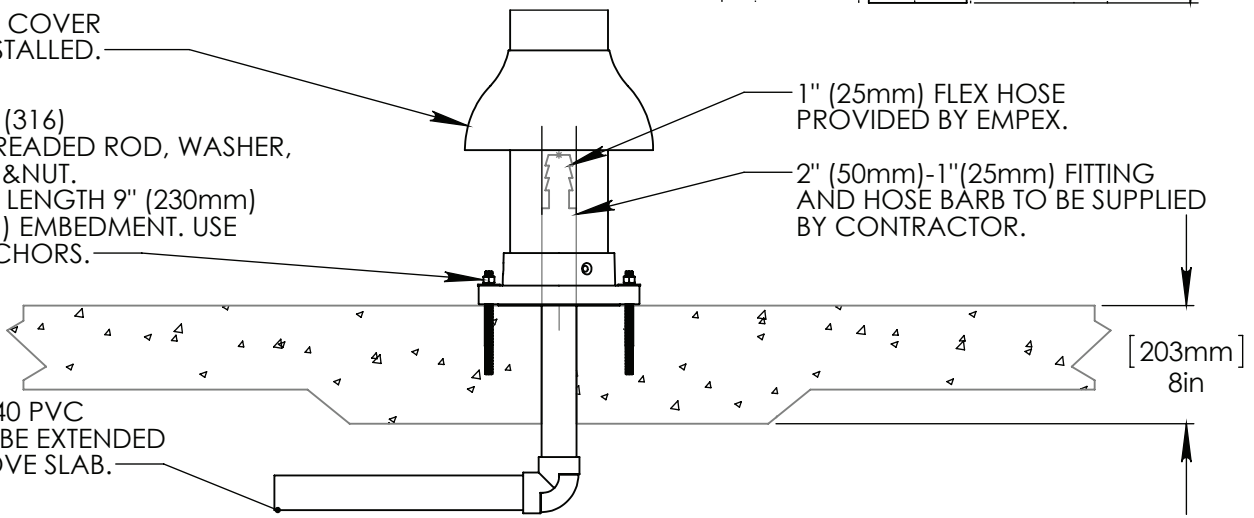

Notes: Overall dimensions of toys are approximate.

© EMPEX WATERTOYS



WATER SUPPLY

30 gpm @ 25 psi
1.89 L/S @ 17.5m

AQUATWEET SMALL

TR962S

9/17/2014

SCALE:
1:25

Sheet
1 of 1

1

2

3

4