

1

2

3

4

A

A

NOTES:

- (1) PURGE ALL WATER SUPPLY LINES TO REMOVE SOLIDS PRIOR TO TOY INSTALLATION.
- (2) PROVIDE ELECTRICAL BOND WITH POOL REBAR.
- (3) INSTALL ALL WATER TOYS PLUMB AND LEVEL.
- (4) PROVIDE STRAINER UPSTREAM OF TOY WITH MAX 1/32" (0.8mm) PERFORATIONS.

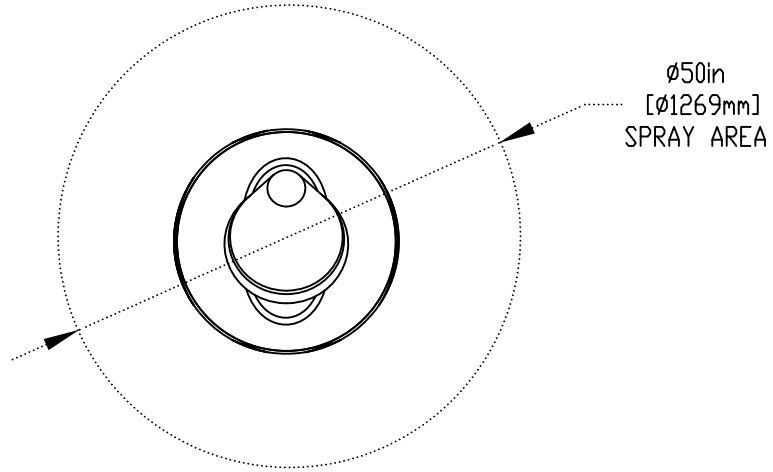

B

B

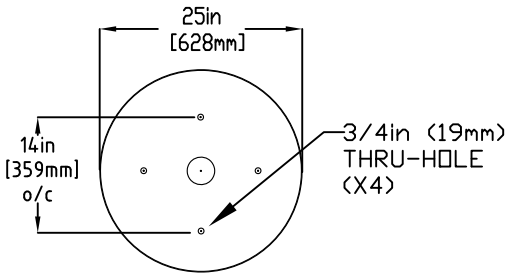

MOUNTING PLATE DETAIL

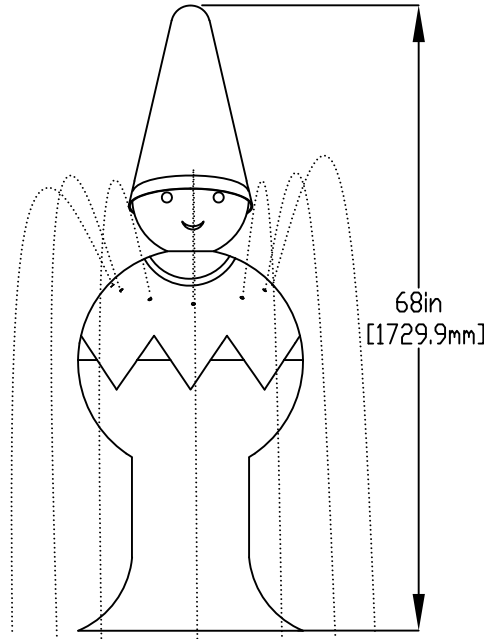

C

C

D

D

1. Bolt insert sleeve
2. Make Plumbing connection
3. Lower Toy & Bolt to Insert

1/2" (13mm) X 8" (203mm) 316SS THREADED ROD, C/W FENDER WASHER, LOCK WASHER & NUT (X4) MINIMUM 6" (152mm) EMBEDMENT, EPOXY SET ANCHOR ADHESIVE TO BE PROVIDED BY CONTRACTOR

1" (25mm) FLEX HOSE PROVIDED BY EMPEX
2" (50mm) COUPLING
2" (50mm) TO 1" (25mm) REDUCER
1" (25mm) HOSE BARB W/SS CLAMP TO BE PROVIDED BY CONTRACTOR

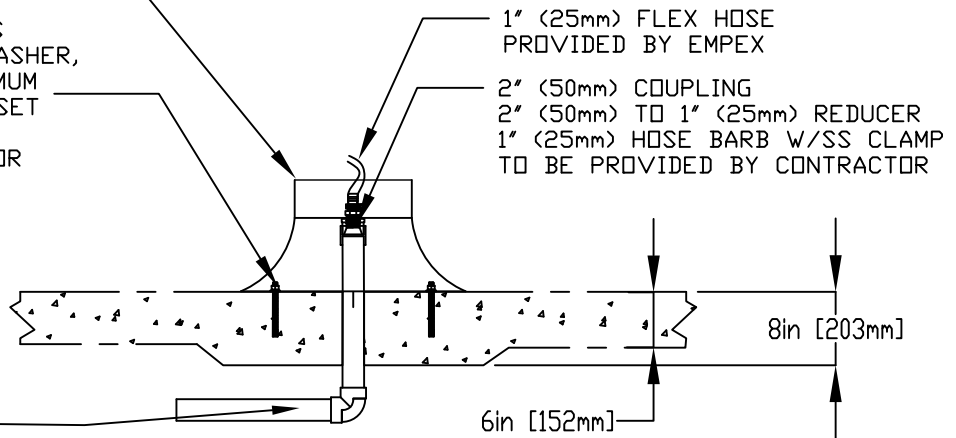

WATERFEED
2"(50mm) PVC SCH 40 PIPE
EXTEND 6" (152mm) ABOVE SLAB

E

E

F

F



Notes: Overall dimensions of toys are approximate.

© EMPEX WATERTOYS

WATER SUPPLY

30 gpm @ 25 psi
1.89L/S @17.5m

AQUAELF

AN102

12/01/2023

SCALE:

Sheet
1 of 1

1

2

3

4