

1

2

3

4

NOTES:

- (1) PURGE ALL WATER SUPPLY LINES TO REMOVE SOLIDS PRIOR TO TOY INSTALLATION.
- (2) PROVIDE ELECTRICAL BOND WITH POOL REBAR.
- (3) INSTALL ALL WATER TOYS PLUMB AND LEVEL.
- (4) PROVIDE STRAINER UPSTREAM OF TOY WITH MAX 1/32" (0.8mm) PERFORATIONS.

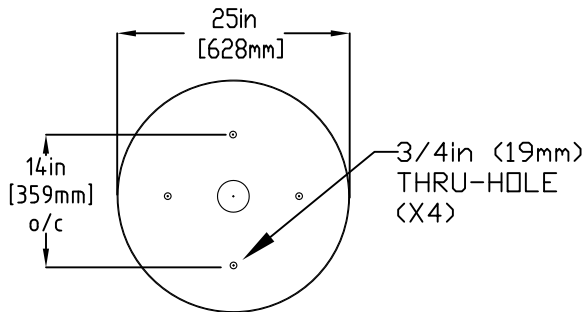
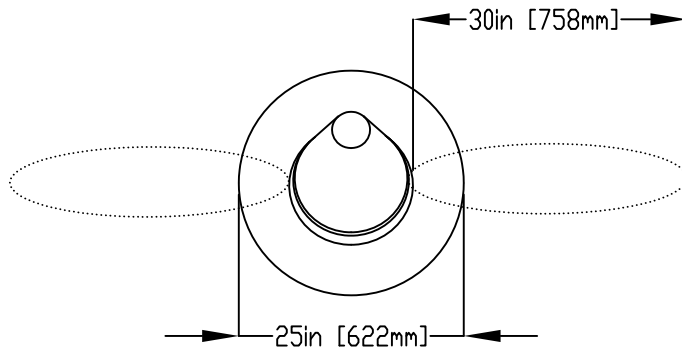

MOUNTING PLATE DETAIL

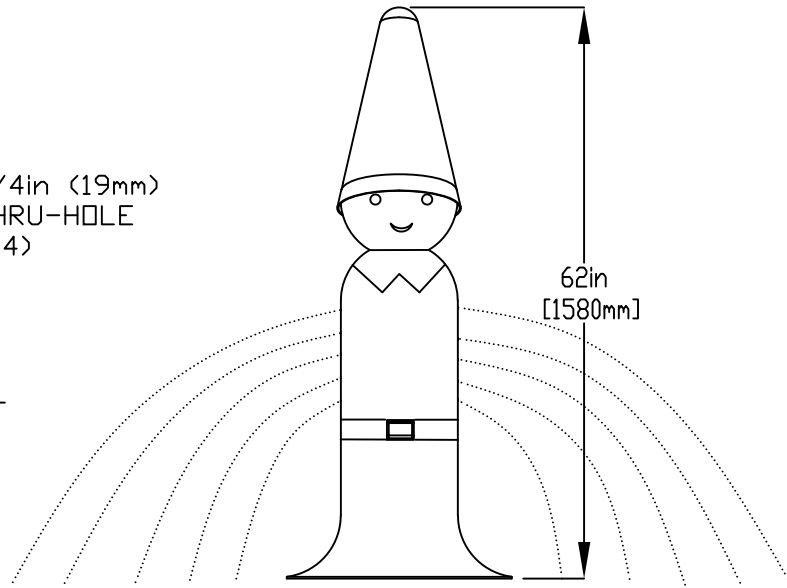

- 1. BOLT BASE WITH MOUNTING PLATE
- 2. MAKE PLUMBING CONNECTIONS
- 3. LOWER TOY AND ATTACH TO FLARE

1/2" (13mm) X 8" (203mm) 316SS
 THREADED ROD, C/W FENDER WASHER,
 LOCK WASHER & NUT (X4) MINIMUM
 6" (152mm) EMBEDMENT, EPOXY SET
 ANCHOR ADHESIVE
 TO BE PROVIDED BY CONTRACTOR

1" (25mm) FLEX HOSE
 PROVIDED BY EMPEX

2" (50mm) COUPLING
 2" (50mm) TO 1" (25mm) REDUCER
 1" (25mm) HOSE BARB W/SS CLAMP
 TO BE PROVIDED BY CONTRACTOR

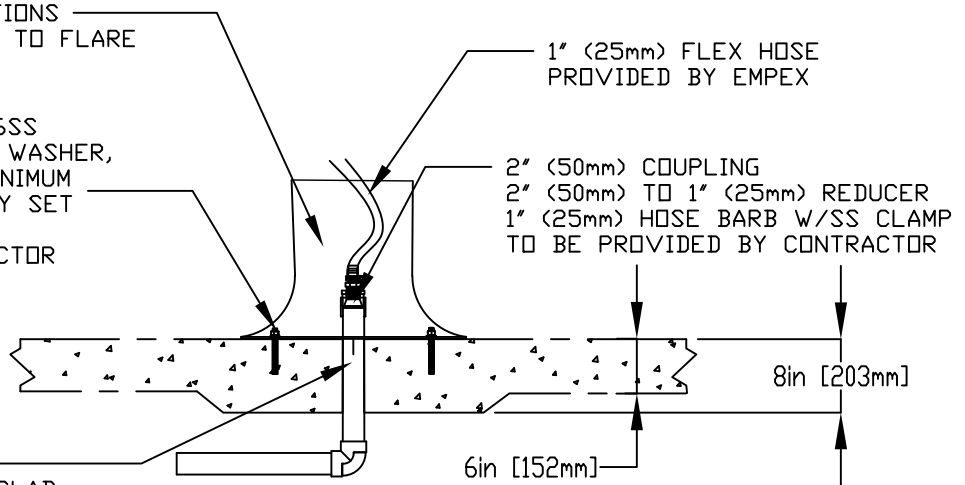

WATERFEED
 2" (50mm) PVC SCH 40 PIPE
 EXTENDED 6" (152mm) ABOVE SLAB.

Notes: Overall dimensions of toys are approximate.

© EMPEX WATERTOYS



WATER SUPPLY
 30 gpm @ 25 psi
 1.89L/S @17.5m

AQUAELF

AN103

12/01/2023

SCALE:

Sheet
1 of 1

1

2

3

4